

Instructions

VM 60 S1-4T



Toni Clark practical scale GmbH

Content

3	Specifications Valach VM 60 S1-4T
4	Engine application
4	Description of the engine
4	Fuel
5	Mounting of the intake RAM tube
5	Mounting the prop shaft
5	Installation
5	Fuel tank
5	The ignition
6	Exhaust header
7	Silencer
7	Crank case venting
8	Carburetor
10	Propeller
10	Tighten the prop screws the right way
10	Safety instructions, the right use of propellers
11	Starting the engine
11	Ignition safety shut off
12	Breaking-in the engine
12	Maintenance
13	Changing the spark plugs
13	Adjusting the valve gap
14	Lubrication
14	Repair
14	Scope of supply
15	Appendix Basics of petrol engines
15	Engine cooling
15	Installation of the fuel tank
16	Fuel tank connections
17	Fuel tubing
17	Installation of the ignition
19	VM 60 S1-4T rear view, Scale 1:1

Last revision: September 3rd, 2014

Specifications Valach VM 60 S1-4T

Design: Four-stroke flat twin engine OHV, 2 valves per cylinder, petroil lubrication.

Capacity: 60 ccm

Bore: 47 mm

Stroke: 35 mm

Distance between

crankshaftaxis/valve cover: 155 mm

Length: 157 mm (engine mount to front side of prop hub)

Prop screw divided circle: 34 mm

Prop screws: 6 pieces M5 Allen Cap screw

Thread prop shaft: M10x1

Engine mount: with four M6 Allen Cap screws.

Weight: 2360 g (including ignition and prop screws)

Idle RPM: 900 RPM

Maximum RPM: 6200 RPM

Recommended RPM range: 4500 to 5500 RPM on the ground (!)

Fuel mixture: 1:30 (1:25 while breaking-in)

Gasoline: At least 95 octane, ideal BP/Aral Ultimate 102

Oil: Valvoline SynPower 2T

Breaking-in time: 3 hours, the first 2 hours with 1:25 mixture

Needle setting:

Low speed needle (L): 2 3/4 turns Setting for breaking-in

High speed needle (H): 3 3/4 turns Setting for breaking-in

Ignition: Valach microprocessor ignition.

Voltage range: 4.8 - 9 Volt, ideal 7.4 V (2 Lipo cells)

Safety shut off: automatically after 1 minute of the prop being stationary.

Spark plug: NGK CM-6

Spark plug gap: 0.4 mm

Valve gap: 0.1 mm

Maintenance intervall:

Checking the valve gap: All 5 hours, while breaking-in after 10, 20 and then 30 minutes.

Lubricating of rocker arm bearings and valve shafts: All 5 hours, while checking the valve gap.

Engine application



The VM 60 S1-4T is intended to be used in model airplanes. Other applications are not permitted!

Description of the engine

The VM 120 B2-4T is a gasoline powered four-stroke flat twin engine, working on the OHV principle with two valves per cylinder and petroil lubrication. The processor controlled ignition makes starting a child's play and provides smooth running in all RPM ranges.

Fuel

For fuel, use unleaded petrol with a minimum of 95 octane mixed with a full synthetic two stroke oil.

We use and recommend **ARAL Ultimate 102**. It contains no bio-ethanol, the shelf life of the mixture is much longer, the odor is reduced, the burning more gentle.

Attention with E10 Fuel: The shelf life is much shorter. Mixed fuel has to be used within 30 days!

The first two hours of the breaking-in time has do be done with a mixture with a ratio of 1:25, this equates 4% oil in the gasoline. After that we recommend a mixture of 1:30. The whole breaking-in time is approx. three hours.



After many tests, the oil we recommend for the Valach Motors four stroke engines is **Valvoline SynPower® 2T**.

The extremely high quality BelRay H1R, we use for our two-stroke engines, is not ideal for petrol lubrication in four-stroke engines. BelRay H1R burns off very well and deposit free, but it does not blow down past the piston rings into the crankcase as well as **Valvoline SynPower® 2T**. The design engineer does not recommend to use Castrol oils, because they built up far too much carbon.



Do not use ready mixed synthetic odorless chain saw fuel. Use the four-stroke version without oil and mix it with **Valvoline SynPower® 2T**.

Breaking-in mixture:

5 Liter gasoline and 200 ml oil , this 5 Liter are enough for the breaking-in.

Mixture afterwards:

5 Liter gasoline and 170 ml oil, or per Liter gasoline 33 ml oil.

Mounting the intake RAM tube

The loosely supplied intake RAM tube , has to be mounted to the engine in any case! Without it, the engine runs too lean, even with wider opened jet needles!

The carburetor screws have the right length to attach the intake RAM tube. Without the intake tube, the screws are too long and the carburetor sits too loose on the engine.

Mounting the prop shaft

The prop shaft is supplied loose with the engine, because of ease of transport. The prop shaft has to be screwed into the hub with a medium strength thread locking adhesive (Loctite 642). At first screw all 6 prop screws fully into the hub. Then screw both prop nuts onto the shaft and lock them against each other. Apply the thread locking on the thread of the prop hub, screw it in the hub and tighten it with the help of the two nuts. It is sufficient to hold the hub with a strong hand while tightening the prop shaft.

Installation

Mount the engine with M5 screws with matching length directly onto the firewall. Do not use the engine if any of the four screws is not in place. Check regularly, if all screws are securely tightened. We recommend the use of lock washers DIN 127 or a thread locking with a medium strength (Loctite 642).

To move the engine forward if necessary, stand off's are supplied with the engine. Do not use longer standoffs, they are torsionally not stiff enough and cause a lot of vibration in many circumstances. If necessary build an engine dome.

Do not use rubber shocks! They are not needed with this engine and you save a lot of trouble with unsuitable rubber motor mounts. Mounted rigid, the VM 60 S1-4T runs much smoother than any two-stroke engine.

Fuel tank

The fuel consumption of the VM 60 S1-4T is very low, compared to two-stroke engines. A 300 ml fuel tank is enough for 15 minutes of flying. We recommend the use of a felt clunk filter! Secure the Tygon® F4040 fuel tubing on the connections with 0.5 - 1 mm copper wire – wind it two times around the tubing and twist it a few times.

The ignition

Mount the ignition Hall sensor with two M3 screws on the crankcase so that the sensor reaches over the prop hub. Secure the screws with low strength thread locking adhesive.

Connect the ignition with a battery with a voltage range from 4.8 V to max. 9 V and a minimum capacity of 1000 mAh. The best choice are two LiPo cells (2s, 7.4 V). **In any case, and this is important, just use a switch and no voltage controller!**



Never switch the ignition on or connect the battery, when any of the spark plug caps is not connected with the spark plug!

Mount the ignition protected against vibration into your model. Do **not** wrap the ignition cables with spiral tubing. This makes the cables heavier and as a result more prone for vibration, especially where the spiral tubing ends at the spark plug connector.

Exhaust header

With four-stroke engines feasible header lengths have almost no effect on power, but header length has a pronounced effect on the sound. When the engine is run without a silencer, a longer header produces a "warmer", more pleasing exhaust tone.

Silver solder 18 mm stainless steel bend #7281 onto the supplied steel flange or to our special oval flange #7336. Connect the silencer with our flexible stainless steel exhaust tube #3881 to the widened up end of the header. Silver solder the tube on the header. On the end to the silencer it is sufficient to „screw“ the tube clockwise on the silencer, and fix it by turn it counter clockwise. The diameter of the wrapped tube widens or narrows while twisting it, so no clips are necessary. We can supply the stainless steel bends.



Do not use Loctite! Attach the header with M4 Allen cap screws and spring washers DIN 127A to the cylinder heads.



Stainless steel header #7673 specially made to fit the VM-60 into our big Tiger Moth. The silencer is mounted behind the cylinder.

Silencer

Compared to two stroke engines, the VM-60 S1-4T needs relatively small silencer. In our Tiger Moth we use the very compact stainless steel silencer #7670 with front exhaust. Only 175 mm long it should fit into nearly every model. With this silencer the engine develops much power, combined with a warm pleasant sound. We can supply a silencer with rear exhaust #7675 as well. If you want a very quiet engine, the stainless steel silencer #2596 for the ZG 26 is the right choice.



Crankcase venting

The tube on the crankcase venting is used to remove the surplus oil out of the engine. Do not extend the tube or reduce the diameter.

Hint: I guide the rests of the oil into a plastic container, that is filled with absorbent cotton wads (from the dentist). The oil is absorbed by the cotton and will not come out while the wildest aerobatic maneuvers. I use an empty 100 ml bottle of our silver solder flux H1. The cap has a double sided tank nipple and eight 3 mm venting holes in it.



Do not omit the venting holes, they are absolutely necessary! The small tube on the nipple guides the oil in the middle of the cotton in the bottle. I attached the container with Velcro into the model, so it can be easily removed for draining. The bottle must be placed lower than the crankcase vent!

Carburetor



The loosely supplied intake RAM tube , has to be mounted to the engine in any case! Without it, the engine runs too lean, also with wider opened jet needles!

The correct tuning of the engine can only be achieved, with a mounted intake RAM tube. The intake tube saves fuel and keeps the model under the cowling cleaner. It is not attached on the delivered engine, only for transportation reasons.

A pre adjusted Walbro carburetor with two jet needles (L: low speed needle and H: high speed needle) is mounted on the engine. The low speed needle influences the throttle response from idle to about 40% of the maximum RPM.

The **basic adjustment** for the high speed needle is 3 3/4 turns open (screw the needles carefully in and screw them out 3 3/4 turns) and 2 3/4 turns for the low speed needle. The fine-tuning for best performance and throttle response is made after the engine is mounted in the model.

The diaphragm pump into the carburetor is supplied with the pulsing crankcase pressure by a tube. Keep an eye on the condition of this tube, because it is essential for the correct functioning of the engine. You can read detailed instruction under "Maintenance".

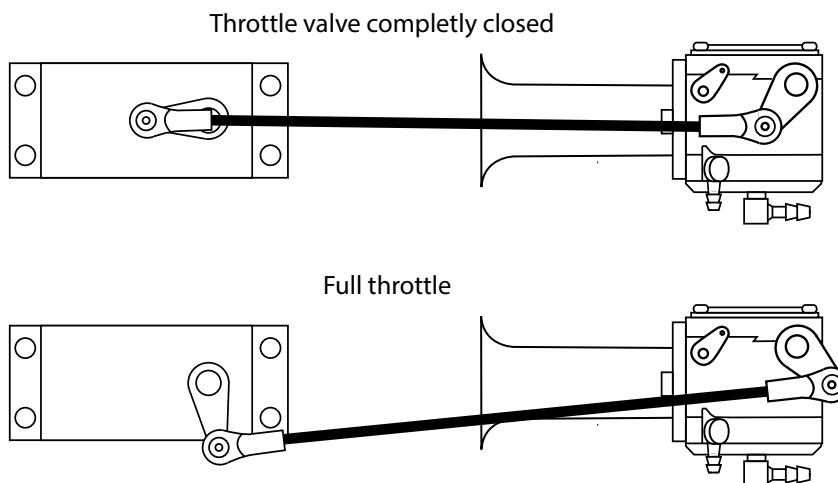

Throttle linkage to improve the throttle response from idle.

Hint: Adjust the response time of your throttle servo in your transmitter to 1 sec. from idle to full throttle. Other than expected, the throttle response will be faster and of course more reliable, especially from low idle. The response time from full throttle to idle can be on full servo speed.

It is a good idea to make a throttle linkage like the one showed above. The throttle valve will move slower on idle than on full throttle. As a result the engine will accelerate faster and more reliable from low idle. The use of a throttle curve in your transmitter

will NOT have the same effect, because it has no influence on the servo speed. For example, if you move the throttle stick fast from idle to full throttle, the transmitter will not follow the throttle curve, it will only transmit the command „full throttle“. The throttle valve will open on the full servospeed. The servo arm should have a length of about 14 mm to maintain the full servotrack.

To link the throttle valve drill a 2 mm hole into the existing arm and attach a ball joint. Keep the throttle linkage as light as possible, a carbon rod is the best choice. By no means remove the spring. The life-time of the throttle valve bearing of the carburettor depends on this spring and a light linkage. In the appendix you can see several pictures of my installation of the engine in our big Tiger Moth.

I actuate the choke with a servo too. This gives me the opportunity to shut off the engine, without using an electronic switch.

Propeller

The best RPM range for the VM-120 is 4500 to 5000 RPM on the ground.

Suitable Fiala-2-blade Propellers are:

24x10" 24x12" 26x10"

Suitable Fiala-3-blade Propellers:

22x12" 24x10"

With the smooth power stroke of the VM-60, it usually is not required to use 3-blade propellers. Their efficiency is about 5 % less. You would experience a noticeable reduction in performance, when using a 22x12" 3-blade instead of the 24x12" 2-blade prop.

Hint: Drill the mounting screws of the propeller from both sides. Start from the backside and then go on on the front side. This will make your holes more precise.

Tighten the propeller screws the right way

Insert all six prop screws and tighten the screws diametrically opposed, until they have the same torque.



The M10x1 Nuts are **not** intended to mount the propeller on the engine. They can become loose, fly around and cause serious injuries.

Safety instructions, the right use of propellers



Do not stay in front or to the side of the propeller longer than needed. Make absolutely clear to spectators, that they have to stay behind the propeller area.



Check the propeller before every flight. Do not repair propellers or use damaged propellers.



Check every (!) day, before the first start, if the six M5 prop screws are tightened.



Check the length of the M5 prop screws, before you attach the propeller. On the one hand, they have to be long enough to form a reliable screw joint, on the other hand they do not have to be too long, to prevent them from bottom out in the blind hole. Keep in mind, especially wood props shrink a little, every time you tighten the prop screws. Even if you tighten them up several times, the screws have to be short enough.

For a (hopefully) better understanding: The friction between prop hub and the backside of the propeller holds the prop. The friction is achieved by the contact pressure of the six screws. If the friction is not sufficient the propeller can move a bit, as a result the six screws are loaded in bending mode with every revolution. Although this movement is very small at the beginning, the screw will not withstand this alternating stress. The screws will "sheer", as most modelers call it. The truth is, that these screws will break because of fatigue in the same manner as a spoon, that is bent by the clever Uri Geller a few times.

Starting the engine

To start the engine, pull on some working gloves. Never start the engine alone! Ask a reliable and strong person to hold your model. Do not trust mechanical anchorage in the ground, on fences or something similar. Approx. 10 kp of thrust is an enormous force!

The first start of the day:

1. Close the Choke valve completely.
2. Open the throttle a bit more than required for normal idle.
3. Ask a reliable and strong person to hold your model.
4. Switch on the ignition
5. Flip the engine, without any extra sucking in! The engine will start, when the carburetor has sucked in enough gasoline with closed choke and will stop after a few revolutions.
6. Flip the engine a second time with closed choke.
7. Open the choke.
8. Flip the engine, until the engine starts to run constantly.
9. Run the engine with increased idle for about 10 seconds.
10. Accelerate to 25% throttle, to warm the engine up for about 30 seconds until you taxi to the runway.

If your engine had run during the last hour:

1. Close the choke valve completely
2. Open the throttle valve a bit more than required for normal idle.
3. Ask a reliable and strong person to hold your model.
4. Flip the engine once with the ignition switched **off**.
5. Open the choke valve.
6. Switch on the ignition.
7. Flip the engine, usually it will start immediately.
8. Warm up the engine as described above.

Ignition safety shut off

Due to a safety shut off feature, the ignition will automatically shut off after one minute without turning the propeller. This safety feature can easily become a trap, if you get disturbed by anyone, while starting your engine. If you go on after a minute and forgot to switch the ignition off and on again, you will flood your engine more and more with every flip...

Switch off your ignition with the battery switch, after every flight. A small current is still flowing, when the ignition is on stand by. This small current will discharge your battery. **The ignition has to be switched off after every flight with the ignition switch!**

Breaking-in the engine

The engine is factory tested and pre adjusted. While breaking-in the engine the level of wear is increased. While breaking-in use a mixture of 1:25.

We recommend for the first 30 Minutes a maximum of 3000 RPM. Afterwards you can increase up to 5.000 RPM for a few seconds. Change continuously the throttle setting and keep an eye on the engine temperature the first two hours. Change the mixture to 1:30 and load the engine normally. Usually the breaking-in procedure lasts three hours.

Maintenance

The construction of the engine is laid out for a minimum of maintenance effort. The valve gap has only to be controlled after all two or three operating hours after breaking in.

Lubricate the rocker arm bearings and the valve shafts while you are at it, if the engine is **not** mounted upside down..

While breaking in, the valve gap has to be checked at shorter intervals, check it after 10 minutes the first time, then go on for about 20 minutes and check it again, after that, check the valve gap every 30 minutes, until after about five hours only minor changes will occur. Afterwards it is enough to check it every five hours.



The backside of the crankcase is connected to the carburetor with a tube. This tube guides the alternating crankcase pressure to the diaphragm pump into the carburetor to actuate it. If you deploy the engine for aerobatics, with long vertical climbs and hover maneuver like me, then have a regular look (at least while breaking-in) on this tube. Oil in this line damps the alternating pressure and reduces the pump capacity. As a result the engine runs too lean and can stop. Do not worry too much about it, this is just meant as a hint to be prepared!

The following points have to be kept in mind as well, to guarantee a long faultless life:

Condition of the ignition battery.

Contact gap of the spark plugs, it should be 0.4 mm.

Change the spark plugs, if the electrodes are burned away.

Hint: It is a good idea to change the sparkplug (NGK CM-6) after breaking-in the engine. The higher metal abrasion during breaking-in is likely to collect on the insulator of the sparkplug, it will then short the HT to earth.

Clean your engine occasionally with „WD 40“, especially the valve train needs this. Afterward lubricate it as described in the section “Lubrication” with chain lube or our Würth „HHS 5000“.

Changing the spark plugs

Never tighten the spark plugs on a hot engine! The tension caused by the different cooling can damage the thread in the cylinder head.



Screw the spark plugs in by hand until the gasket makes contact with the cylinder head, and tighten them with a wrench a 1/4 turn.

Adjusting the valve gap

On a **cold** engine the valve gap should be 0.1 mm. The adjustments are made with the supplied feeler gauge, the WS 7 wrench and the WS 2 Allen key.

1. Remove both valve covers.
2. Turn the crankshaft (on the propeller) until the valves on the cylinder overlap. This means, that both valves are slightly open, i.e. one valve begins to open, while the other starts to close. Turn the crankshaft one revolution. In this position of the crankshaft, you can adjust the valve gap of the cylinder.

3. First off all measure the gap with the feeler gauge (0.1 mm). The gap is OK when the gauge can easily (without strong resistance) be pushed through the valve end and the rocker arm. The gap is too big, if no friction can be felt. If the gauge sits tight, and can only be pushed with a lot of resistance, the gap is too narrow.

4. Loosen the locking nut and place the feeler gauge between valve end and rocker arm.

5. Turn the adjusting screw with the Allen key in small steps, until the gauge can be pushed with a little resistance through the gap.

6. Tighten the locking nut and check the gap again with the feeler gauge. It is possible, that the gap changed after locking the nut.



This photo series shows the adjusting of the valve gap with the help of the feeler gauge.

Lubrication

The lubricating of the rocker arm bearings is only necessary if the engine is **not** mounted upsidedown. It makes sense to lubricate the engine when adjusting the valve gap. Use a Off-Road chain lube with a temperature range of at least 150°C. After many tests, we use the **Würth „HHS 5000“**, it contains PTFE and has a temperature range up to 250°C.

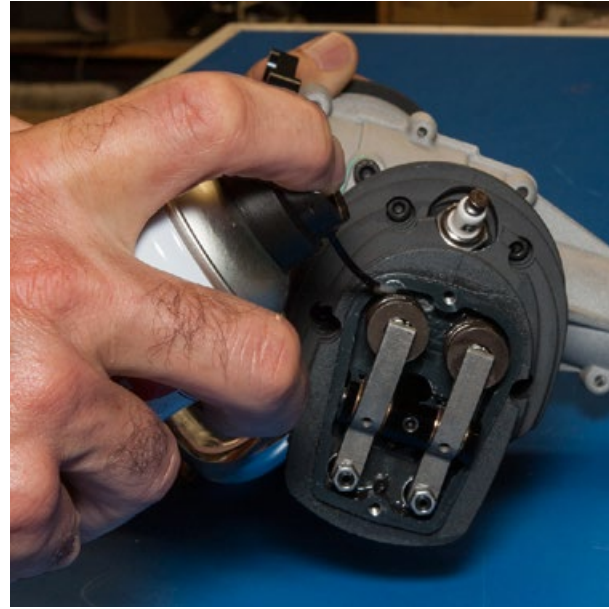
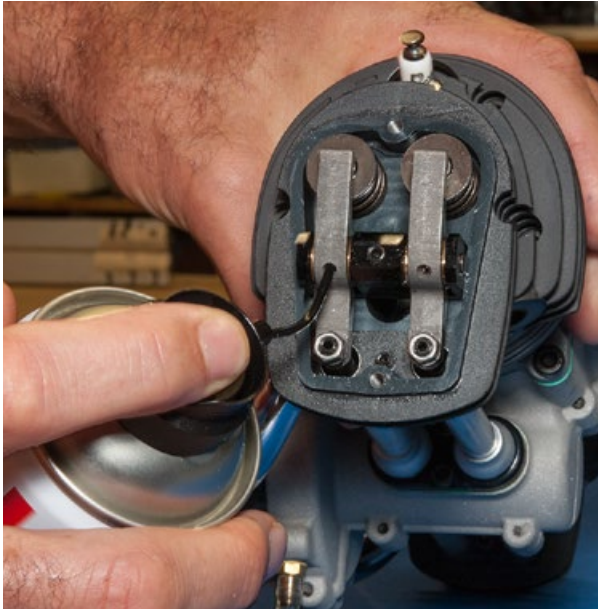

The pictures show the lubricating points on the rocker arm bearings, the valve guides and rocker arm tips.

Repair

If you have any trouble with your engine, feel free to contact us:
 Toni Clark practical scale GmbH
 Zeiss-Str. 10
 D-32312 Lübbecke
 Tel. 0049 (0) 5741 5035 Fax. 40338
 e-mail: reinsch@toni-clark.com

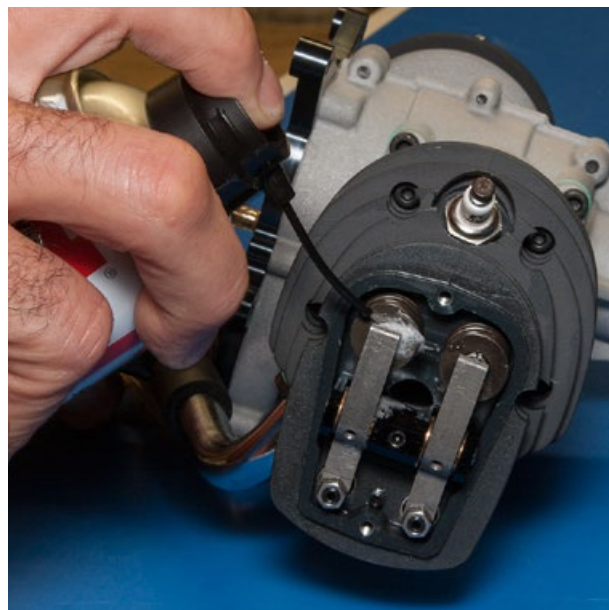

Scope of supply

Engine
 Instructions
 Prop screws
 Spark plug wrench
 WS 7 wrench
 WS 2 Allen key
 exhaust gasket

Feeler gauge 0,1 mm
 Ignition
 Prop shaft
 Prop shaft mounting nuts
 Prop washer
 exhaust flange

Appendix Basics of petrol engines

Engine cooling

To cool the engine, it is not necessary to cut big holes into the cowling, but you have to ensure, that the air flows around the cylinders before it leaves the cowl. Do not forget: The air finds the way with the least resistance, unfortunately this is mostly not the way through the cooling fins. The best material to make baffles from is balsa, it can be positioned close to the engine, as it will grind in, it will not cause interference and it is not sensitive to vibrations.

Air, which flows in a distance of more than a few millimeters from the cooling fins has no effect on the cooling of the engine! In other words: The worst cooling is achieved by a cowling with a huge volume, a big intake and no attempt to force the air through the cooling fins of your engine.

Installation of the fuel tank

It is better for the fuel tank to be built into the model at a level above that of the carburetor. The carburetor has non-return valves fitted, so that the fuel cannot run out through the carburetor as long as the engine is not running. For starting, it is better when the fuel line is full with fuel. With the engine running, it does not matter how long the fuel line is. You can install the tank anywhere you please in the model, at the CG position for example. But keep the fuel line as straight as you can. Avoid bends that will hold air bubbles.

It is impossible to prevent the fuel in the tank from foaming. This foaming means you must use our special cotton felt clunk filter - omit this clunk filter and your engine will draw more air than fuel. Model aircraft fuel filters are useless for petrol engines; the transparent automotive paper element fuel filters are also useless. The former have too coarse a mesh, and the latter have a large capacity, allowing air to accumulate and thereby causing the engine to stop, due to the sudden ingestion of this accumulated air by the carburetor. The second and very important reason for using our cotton felt filter is that in petrol there is always a certain amount of suspended matter, that is almost impossible to see with the naked eye. This dirt will easily pass through the model filter and build up in the carburetor, mainly in the low speed fuel passages. When this happens, the only cure is a new carburetor.

Fitting a T-piece in the fuel line between the tank and carburetor for fueling will be an obvious mistake to most folks, but we have seen this method of short-circuiting the felt clunk filter in the tank, with the obvious results, more often than one would imagine.

Fuel tank connections

Make two air vents made with fuel tubing, fitted to two single sided nipples in the tanks topside, central at the rear end. These two air vent lines must be led forward over the tank and then down into the fuselage floor at the cooling air outlet of the engine cowling. One of these vent lines (does not matter which) is used to fill the tank.

These two lines are always shut off, with two 3.5 mm self tapping screws 15 mm long with heads removed, while the model is flying or otherwise parked.

Because the threads are so coarse, enough air can enter the tank, but even during violent stunting no fuel will be lost. The saving in fuel is considerable! This system is simple and



100% reliable, also during filling the tank, you will not spill fuel over your model. The double sided tank nipple from the clunk filter is best placed in the middle of the tank cap.

Note: Because of the better visibility on the pictures I used the black tubing. In my models, the lighter Tygon tubing is used. I use the heat resistant black tubing for the smoke nipple on the header.

Fuel tubing

Do not use transparent PVC-fuel tubing! This clear fuel tubing often fits neatly onto the nipples and seals nicely for a short while, but after a fairly short period, this clear tubing becomes hard and expands a little in the process, due to the action of the petrol. This tubing then moves due to engine vibration, allowing air to enter the fuel line. It is impossible to seal this PVC tube satisfactorily.

Our specially made, thick-wall Neoprene fuel tubing is fairly soft and can be sealed perfectly at the nipples with 0.5 mm copper or brass wire, by being wound twice around the tubing and twisted together. Do not be tempted to use nylon tie straps or small Jubilee clips to seal the fuel lines, these straps and clips do not exert pressure right around the tubing, they only serve to pull the tubing into an oval shape on a round nipple. The black fuel tube is very tough and due to having a very thick wall, it is not easily kinked.

A very good alternative tube is the transparent yellow **Tygon® F-4040** tubing. It is much lighter and does not expand in contact with petrol, also you can see air bubbles in the fuel. You must use more care in laying this Tygon tube in the model to ensure that there are no sharp bends. This tube is not especially heat resistant, therefore it follows it must not make contact with any hot engine parts.

Installation of the ignition



The microprocessor Ignition is protected with a tough metal case and the electronics inside are encapsulated to protect against vibration. In spite of this it is not a good idea to simply mount the ignition box onto the firewall with a couple of cable ties. I mount the ignition on a "sandwich dampener" made from 3 mm double-faced adhesive tape (mirror tape) and the especially fluffy Tesa Klettband (Velcro).

Please install all components of the ignition, including the ignition battery as far away from the remote control components as possible.

Please install all cables with greatest care. Especially the high voltage ignition cables should not rub anywhere. Only an undamaged insulation can restrain the high voltage of about 20.000 Volt. If the screening is damaged, because the cables rubbed on a cutout in the cowling, the insulation of the cable will get damaged or at least weakened. The ignition voltage will not discharge at the spark plug anymore, but rather will strike through the screening at the weak point. The engine will misfire and because of the (second) discharger the radio gear will be interfered very serious!

Use only knife edge contact switches such as our switch order no. #2024. Toggle switches with roller contacts are not suitable as these are intended for 240 V. Used on low voltage, oxidation can occur, this increases the contact resistance and will lead to ignition failure.

Take care with plugging together the JR-plugs and sockets by noting that the colors should line up on opposite sides. It is possible with a little extra effort to push these together with reverse polarity. No damage will be done but the ignition will of course be dead. I tape these plugs and sockets with insulation tape for additional safety.

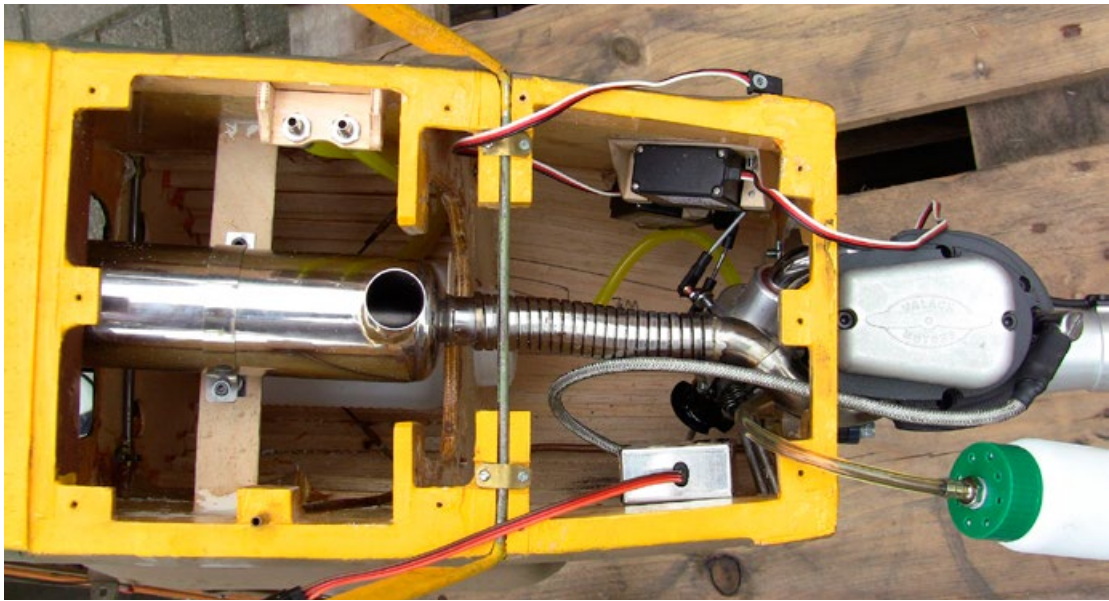

Installation of the VM-60 S1-4T in our big Tiger Moth. The engine fits into cowl by using the 23 mm long standoffs of the VM-120 and the originally drawn position of the firewall. The firewall has a cutout just big enough to allow the carburettor and the exhaust header to project into the fuselage. The air enters th cowl through the original openings, passes the cylinders and leaves the fuselage through the opening in the firewall and the front cockpit. The air is forced to go through the cylinder finns on the side and the rear due to the aproximity of the cowl and the firewall.



To adjust the jet needles I installed a stainless steel tube into the fuselage guiding the screwdriver to each needle. That makes adjusting the needles, while running the engine, a childs play. The holes into the fuselage are covered from the cowling once it is attached.

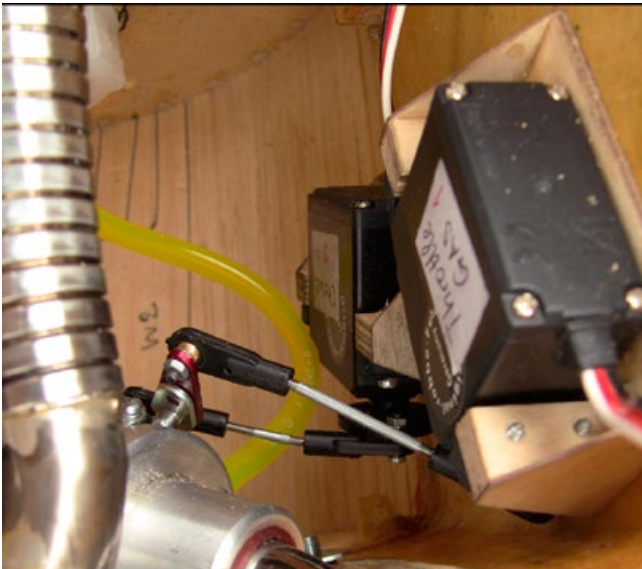

The throttle and choke linkage is made from ball joints and small pushrods. The servos are screwed onto the fuselage wall with scratch build plywood frames, to get a good linkage geometry.

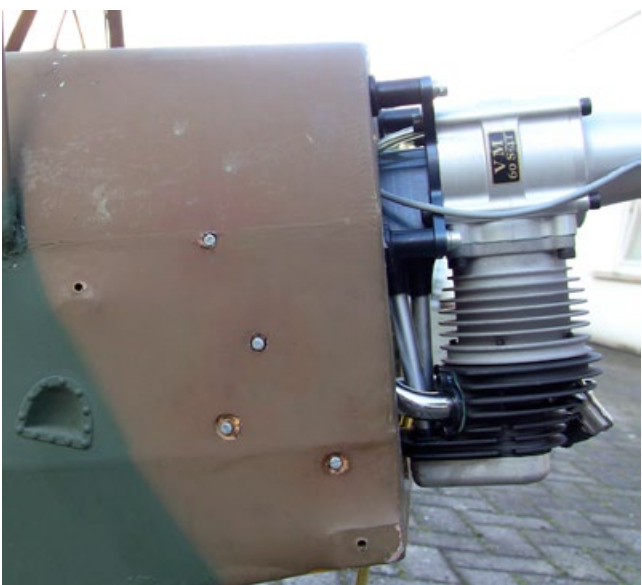

Side view of the VM-60 in our Tiger Moth, clearly visible ist the position of the servoframe screws of the throttle and the choke servo. The throttle servo is the lower one. As is the case with the stainless steel tubes to adjust the jet needles, the screw heads are covered by the cowling after having mounting it.

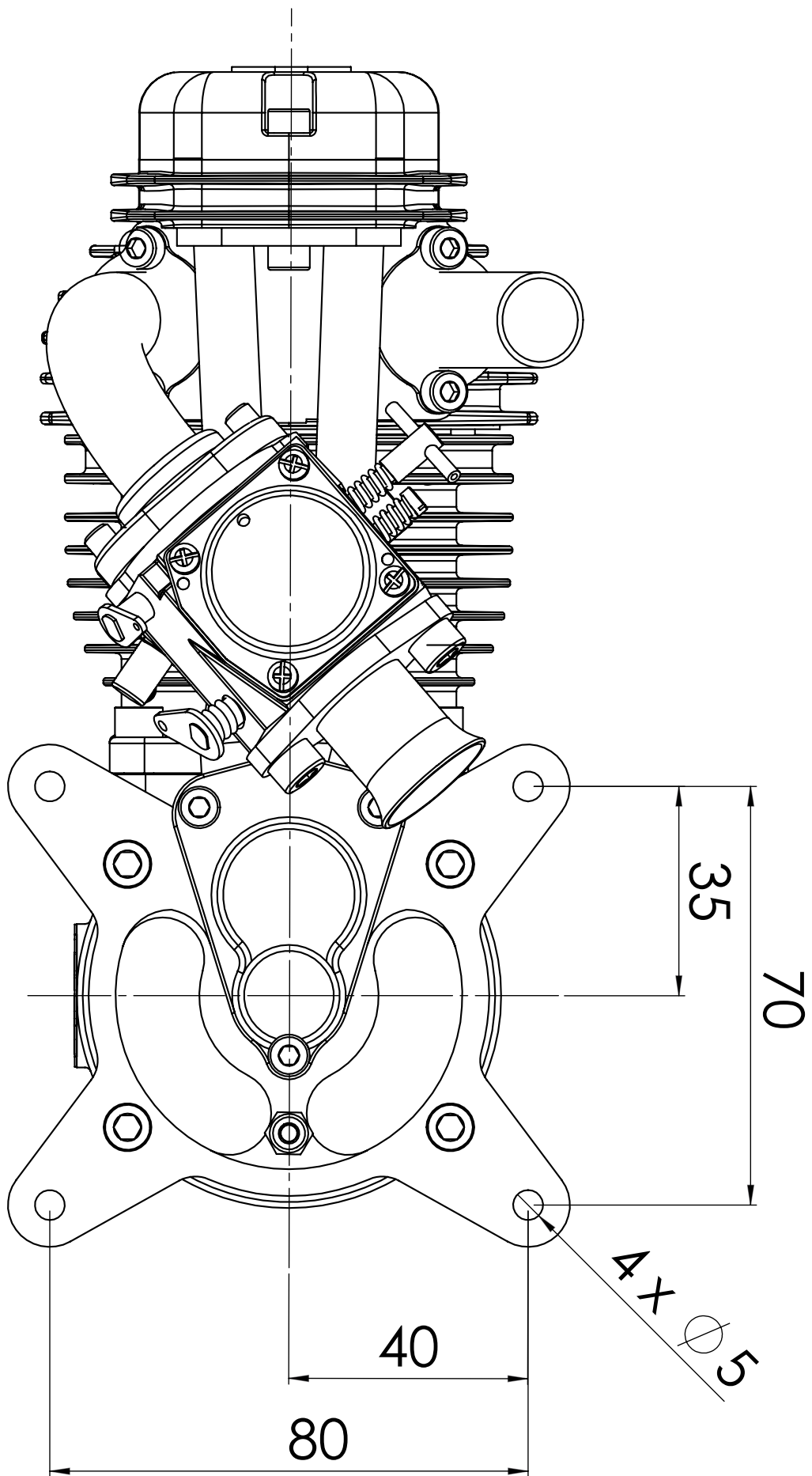

VM 60 S1-4T Rear view, scale 1:1

Instructions Valach VM 60 S1-4T

Toni Clark practical scale GmbH
Zeiss-Str.10
D-32312 Lübbecke

E-Mail: reinsch@toni-clark.com
Tel. 0049 (0) 5741/5035
Fax. 0049 (0) 5741/40338
www.toni-clark.com