

1/3 PAULISTINHA P-56



**Requires: 80 c.c. gasoline engine,
4-channel radio w/ 6 high torque servos.**

Specifications

Wing Span	141 in / 3580 mm
Wing Area	2821 sq in / 182 sq dm
Flying Weight	28.5 lbs / 13000 g
Fuselage Length	91 in / 2310 mm

* Specifications are subject to change without notice. *

Warning! This model is not a toy.

It is designed for maximum performance. Please seek advice if one is not familiar with this kind of engine powered precision model. Operating this model without prior preparation may cause injuries. Remember, safety is the most important thing. Always keep this instruction manual at hand for quick reference.



TWM
The World Models
Manufacturing Co., LTD.
www.theworldmodels.com

FACTORY PRE-FABRICATED
 ALMOST-READY-TO-FLY (ARF) SERIES
 MADE IN CHINA

1/3 PAULISTINHA P-56

INDEX

BEFORE YOU BEGIN.....	P.1
PARTS LIST.....	P.2
ASSEMBLY.....	P.3-P.12
SAFETY PRECAUTIONS.....	P.12

BEFORE YOU BEGIN

- 1 Read through the manual before you begin, so you will have an overall idea of what to do.
- 2 Check all parts. If you find any defective or missing parts contact your local dealer. Please DRY FIT and check for defects for all parts that will require CA or Epoxy for final assembly. Any parts you find to be defective after the gluing process may be difficult to remove for warranty replacement. The manufacturer will replace any defective parts, but will not extend to the parts that are good before gluing to defective parts during assembly. Warranty will not cover any parts modified by customer.
- 3 Symbols used throughout this instruction manual comprise of the following :-



Apply epoxy glue.



Apply instant glue
(C.A.glue, super glue.)



Apply thread locker



Must be purchased separately !



Assemble left and right
sides the same way.



Ensure smooth non-binding
movement while assembling.



Peel off shaded portion
covering film.



Cut off shaded portion.



Drill holes with the specified
diameter (here: 3mm).



Pierce the shaded portion
covering film.



Pay close attention here!



Do not overlook this symbol !



Parts List

1. MAIN WING -- 1 pair
 2. SERVO MOUNTING PANEL (For Aileron) -- 1 pair
HEAVY DUTY CLEVIS PL4112200 -- 4 sets
SCREW PM4x60mm -- 2 pcs
SCREW PWA2.3x8mm -- 8 pcs
M4 NYLON INSERT LOCK NUT -- 2 pcs
HEAVY DUTY HORN BRACKET PL4112400 -- 2 sets
HEAVY DUTY SERVO HORN PL4120300 -- 2 sets
PUSHROD Ø2.3x129mm w/ Threads (For Aileron) -- 2 pcs
SWIVEL CLEVIS HORN FAIRING PL4610010 -- 2 sets
 3. SCREW HM4x20mm -- 12 pcs
COPPER CLIPPER 0.5mm -- 8 pcs
MAIN WING STRUTS -- 1 pair
WING STRUT WIRE D4mm -- 2 pcs
M4 NYLON INSERT LOCK NUT -- 4 pcs
WASHER d4xD9mm -- 4 pcs
WASHER d4xD12mm -- 4 pcs
 4. FUSELAGE -- 1 pc.
STABILIZER & ELEVATOR -- 1 set
SCREW PWM2.5x12mm -- 2 pcs
STABILIZER WIRE Ø4x200mm -- 2 pcs
 5. VERTICAL FIN & RUDDER -- 1 set
 6. TAIL GEAR ASSEMBLY (PL3410022) -- 1 set
COPPER PLATE (For Stays on Tail Fueslage Bottom) 1x12x60mm -- 1 pc.
SCREW PA3x18mm -- 3 pcs
SCREW PWA2.5x12mm -- 2 pcs
 7. MAIN LANDING GEAR -- 1 set
SCREW HM4x18mm -- 2 pcs
SCREW PA3x14mm -- 12 pcs
SCREW PA4x20mm -- 2 pcs
WASHER d4xD12mm -- 2 pcs
WASHER d4xD9mm -- 2 pcs
MOUNTING PLATE 12x20mm -- 6 pcs
ALUMINUM PLATE 3x15x77mm -- 2 pcs
 8. SCREW PA1.7x8mm -- 6 pcs
SCREW PM3x10mm -- 8 pcs
WASHER d3xD7mm -- 16 pcs
M3 NUT -- 8 pcs
COLLAR Ø6.1mm w/ set screw -- 4 sets
LARGE SCALE CAPTIVE AIR WHEELS Ø140mm -- 2 sets
PLYWOOD 2x211.5x193.5mm (Main Langing Gear Cover) -- 1 pair
COPPER CLIPPER -- 8 pcs
 9. BLIND NUT M6 -- 4 pcs
WASHER d6xD15mm -- 4 pcs
SOCKET HEAD SCREW M6x30mm -- 4 pcs
 10. COWLING -- 1 pc.
TRANSPARENT 3D TEMPLATE -- 1 pc.
SCREW PA3x12mm -- 4 pcs
WASHER d3xD7mm -- 4 pcs
SILICON GROMMET d2.5xD8.5mm PL1285135 -- 4 pcs
 11. FUEL TANK 1500cc (PL1121500G-gasoline) -- 1 set
CABLE TIE (For Fuel Tank) 1.5x8x500mm -- 1 pc.
DOUBLE-SIDED TAPE 40x160mm -- 1 pc.
 12. PUSHROD Ø2.3x215mm w/ Threads (For Elevator) -- 2 pcs
SCREW PM4x50mm -- 2 pcs
M4 NYLON INSERT LOCK NUT -- 2 pcs
SWIVEL CLEVIS HORN FAIRING PL4610010 -- 2 sets
HEAVY DUTY HORN BRACKET PL4112400 -- 2 sets
HEAVY DUTY SERVO HORN PL4120250 -- 2 sets
HEAVY DUTY CLEVIS PL4112200 -- 4 sets
 13. PUSHROD Ø2.3x170mm w/ Threads (For Rudder) -- 1 pc.
SCREW PM4x50mm -- 1 pc.
M4 NYLON INSERT LOCK NUT -- 1 pc.
SWIVEL CLEVIS HORN FAIRING PL4610010 -- 1 set
HEAVY DUTY HORN BRACKET PL4112400 -- 1 set
HEAVY DUTY SERVO HORN PL4120250 -- 1 set
HEAVY DUTY CLEVIS PL4112200 -- 2 set
 14. SCREW PM2x18mm -- 12 pcs
WASHER d2xD5mm -- 24 pcs
M2 NUT -- 12 pcs
CLEVIS -- 12 pcs
WIRE Ø1x4200mm -- 1 pc.
FLYING WIRE BRACKET -- 12 pcs
CLIP PIN -- 12 pcs
EYE SCREW -- 6 pcs
COPPER TUBE d2.5xD3.2x8mm (For Rudder) -- 16 pcs
 15. SIDE WINDOWS -- 1 pair
 16. LINKAGE CONNECTOR Ø2.1mm w/ set screw -- 1 set
 17. PLYWOOD 3x196x304mm (For Fuselage Servos) -- 1 pc.
PLYWOOD 3x10x160mm (For Fuselage Servo Stand) -- 2 pcs
BALSA 10x10x288mm (For Fuselage Servo Stand) -- 2 pcs
SPONGE 10x80x200mm -- 2 pcs
THROTTLE PUSHWIRE Ø1.2x480mm -- 1 pc.
PLASTIC TUBE d2xD3xD300mm -- 1 pc.
 18. PILOT PC101110A -- 1 set
SCREW PWA2x12mm -- 4 pcs
COCKPIT BASE PANEL 3x196x444mm -- 1 pc.
WOOD 10x10x443mm (For Cockpit Base Panel) -- 2 pcs
 19. WIND SHIELD -- 1 pc.
M2 NYLON INSERT LOCK NUT -- 2 pcs
SCREW PM2x14mm -- 2 pcs
WASHER d2xD5mm -- 4 pcs
MOUNTING PLATE 5x15mm -- 2 pcs
BALSA ROD Ø8x220mm -- 2 pcs
 20. WING TUBE Ø22x931mm -- 2 pcs
SCREW HM3x30mm -- 2 pcs
SCREW PA3x30mm -- 2 pcs
WASHER d3xD7mm -- 4 pcs
 21. SCREW HM4x15mm -- 2 pcs
WASHER d4xD12mm -- 2 pcs
M4 NYLON INSERT LOCK NUT -- 2 pcs
 22. DECALS: A324DEC -- 1 set
- **COVERING:**
TOUGHLON STL 204 CREAM
LIGHTEX SGX 201 BLACK
LIGHTEX SGX 310 RED

1 Main Wing

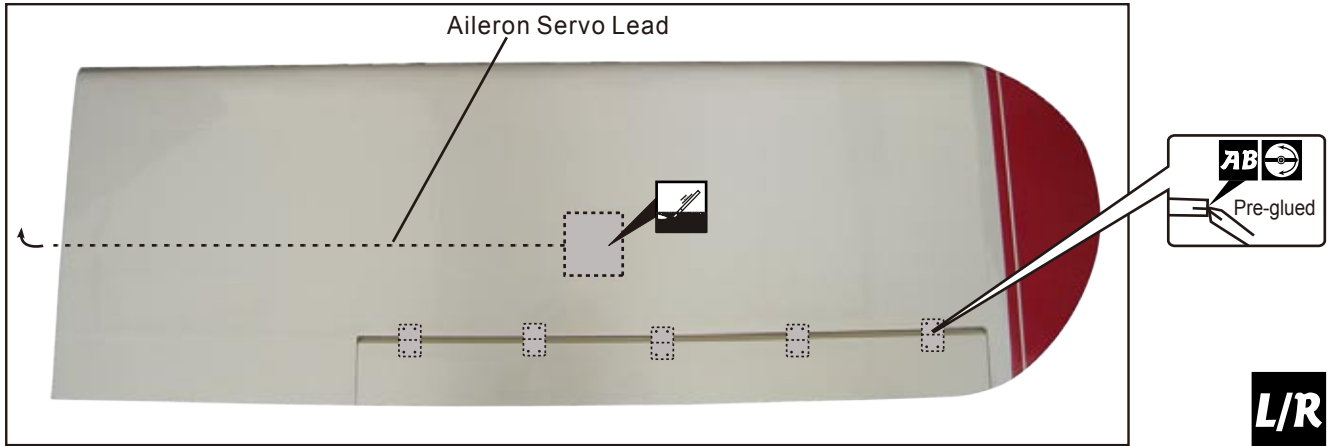

● Bottom View

L/R

2 Aileron servo

- PM4x60mm Screw — 2
- M4 Nylon Insert Lock Nut — 2
- PWA2.3x8mm Screw — 8

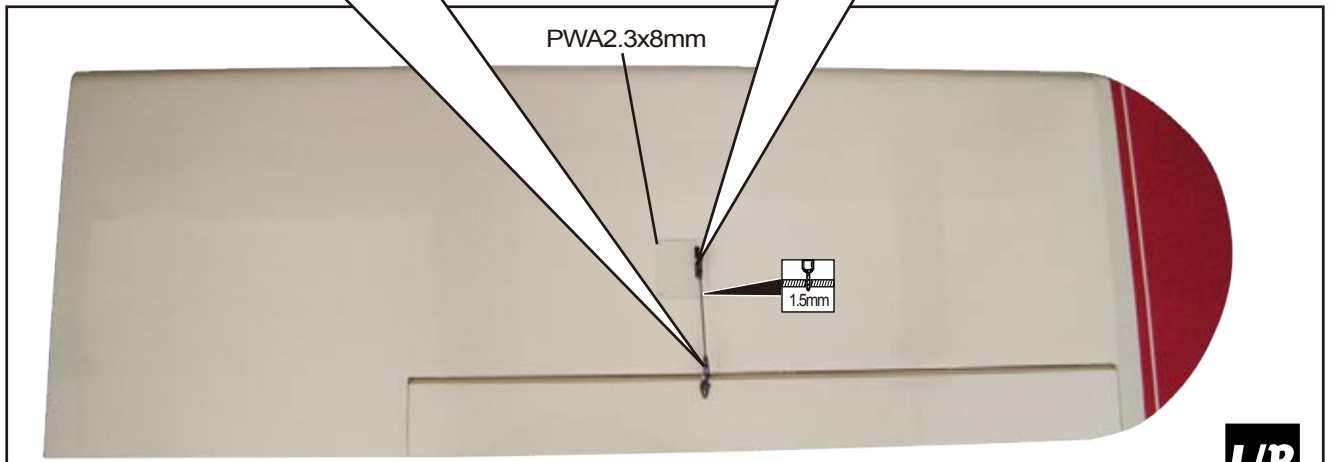
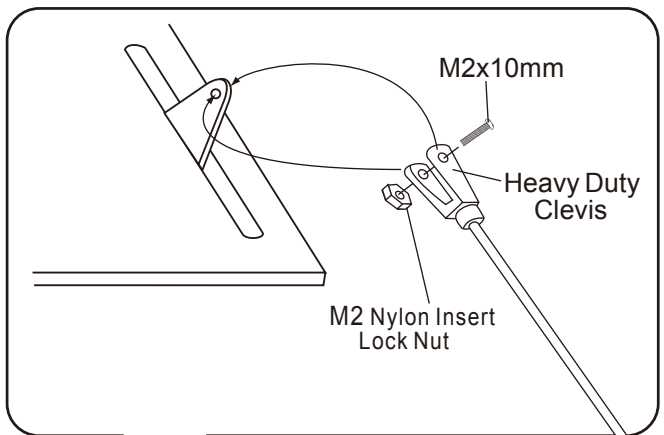
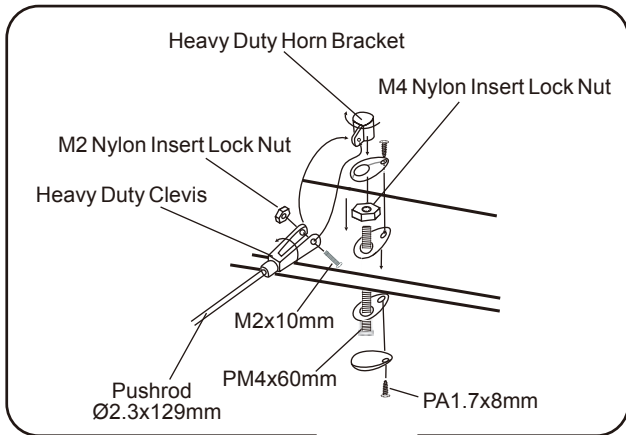
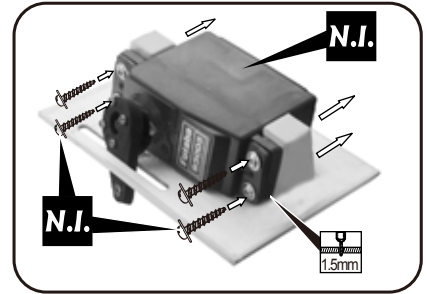
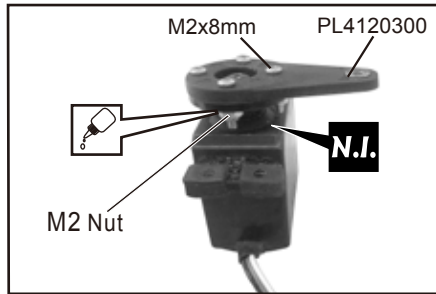

● Bottom View

L/R

3 Wing Struts

- HM4x20mm Screw 12
- d4xD12mm Washer 4
- d4xD9mm Washer 4
- M4 Nylon Insert Lock Nut 4

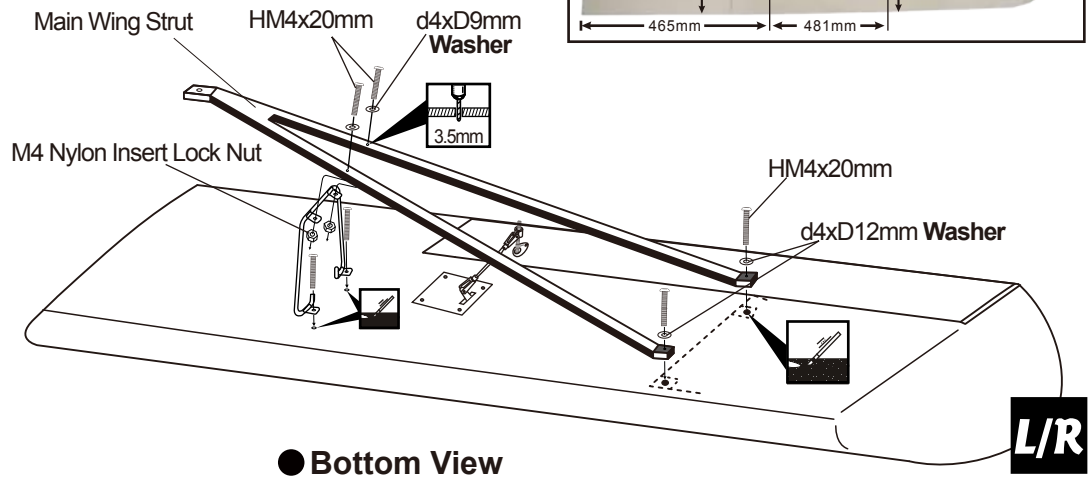

4 Stabilizer & Elevator

- PWM2.5x12mm Screw 2

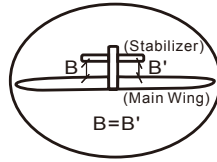

Temporary install the main wing, adjust leveling of the stabilizer to make it as parallel to the main wing as possible.

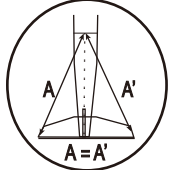
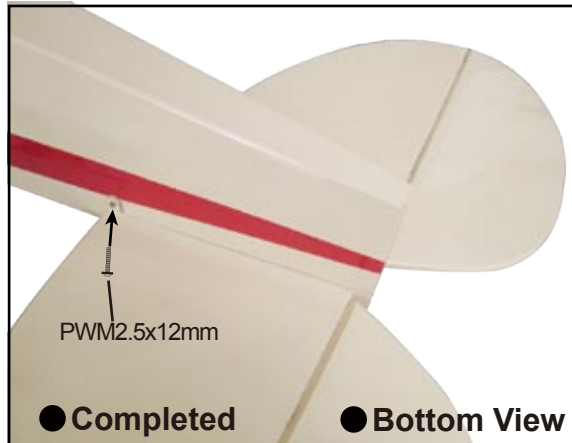
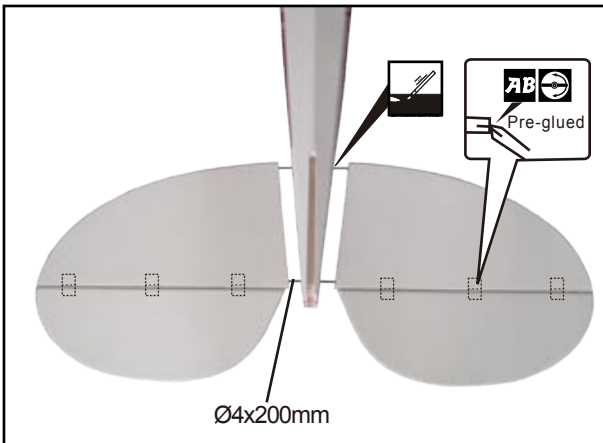

5 Vertical Fin & Rudder



6 Tail Landing Gear

- PA3x18mm Screw — 3
- PWA2.5x12mm Screw — 2



● Bottom View

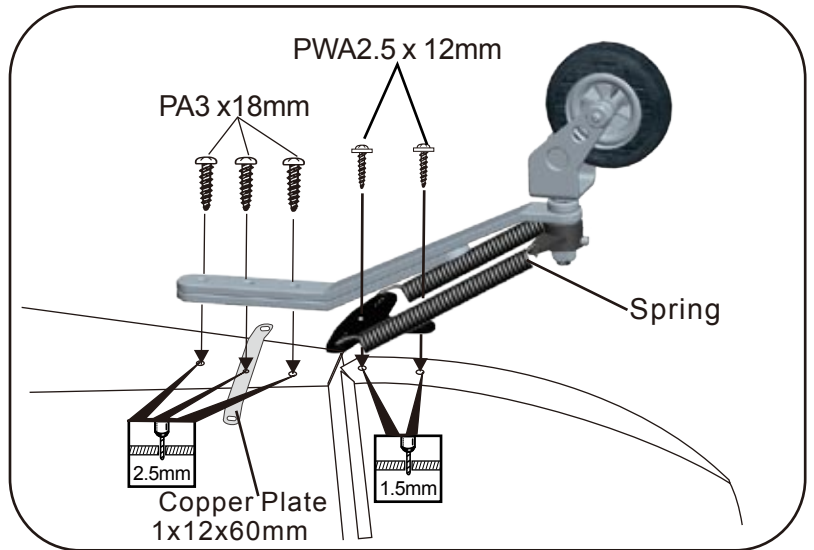

7 Main Landing Gear

- HM4x18mm Screw — 2
- PA3x14mm Screw — 12
- PA4x20mm Screw — 2
- d4xD12mm Washer — 2
- d4xD9mm Washer — 2

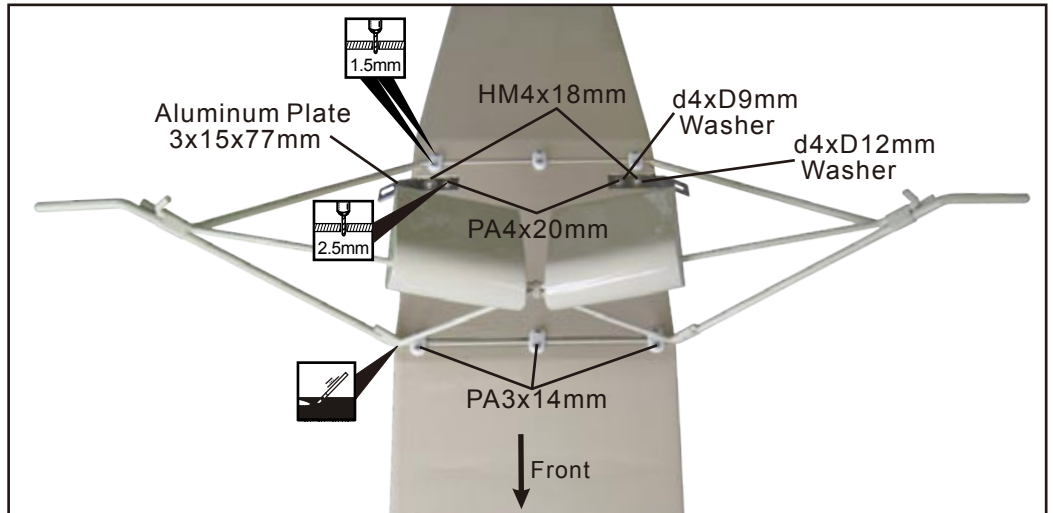

● Bottom View

8 Landing Gear

- 3mm Set Screw — 4
- PA1.7x8mm Screw — 6
- D6.1mm Collar — 4
- PM3x10mm Screw — 8
- d3xD7mm Washer — 16
- M3 Nut — 8

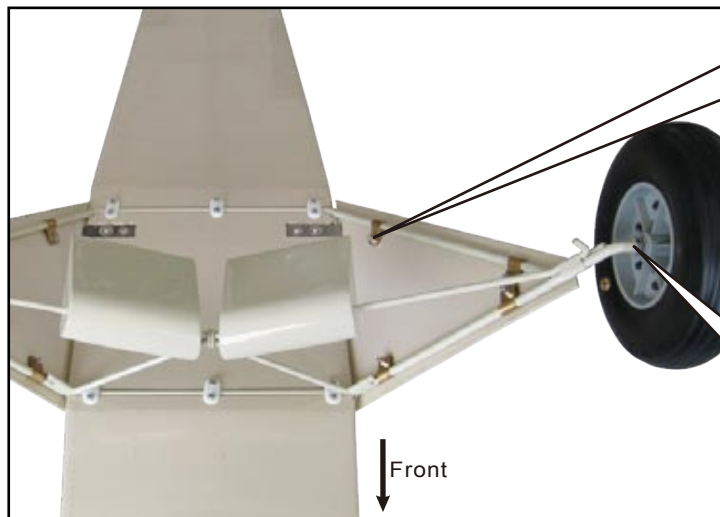

● Bottom View

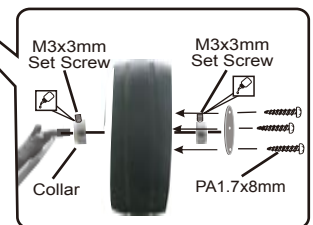
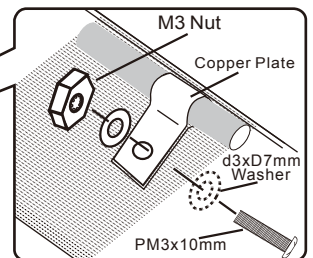

L/R

9 Engine

M6x30 **SOCKET HEAD SCREW**



d6xD15mm **Washer**



M6 **Blind Nut**

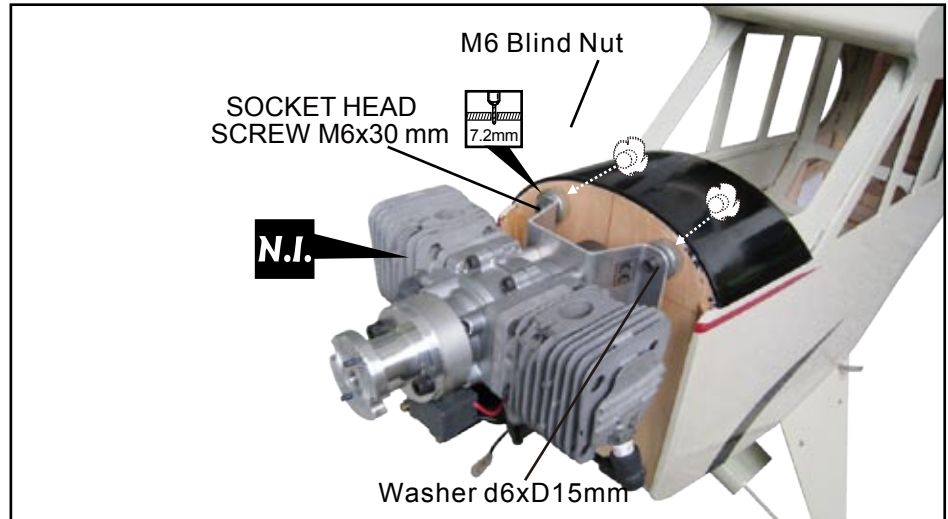
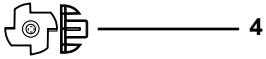

10 Cowling

PA3x12mm **Screw**

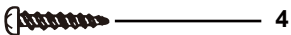

d2.5x8.5mm **Silicon Grommet**



d3xD7mm **Washer**



● Please refer to the attached sheet for usage of the transparent 3D template.

● First insert the grommet to the cowling then apply screw.

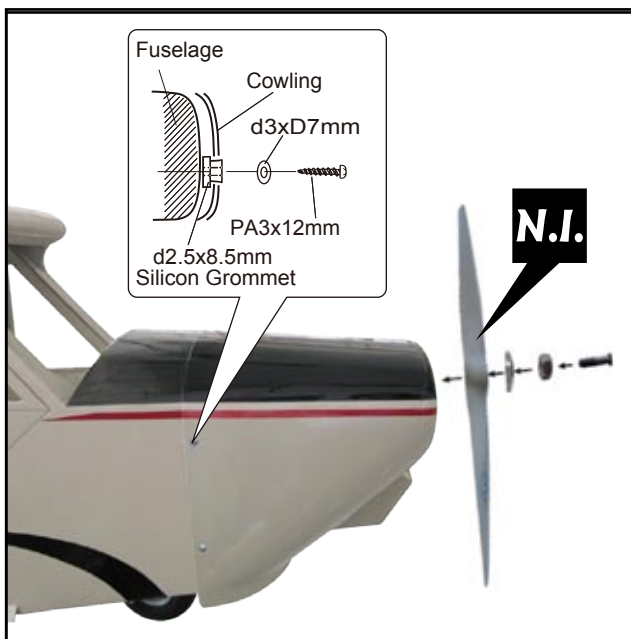
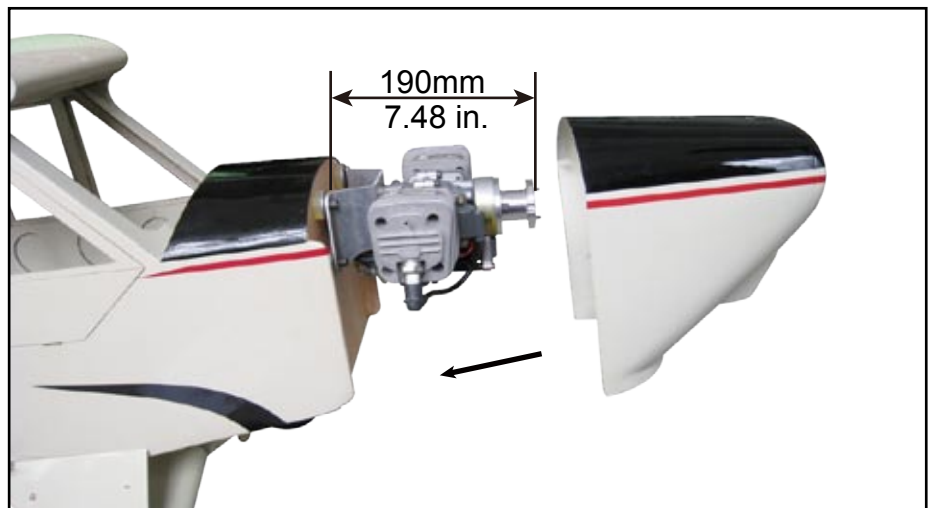

11 Fuel Tank

CABLE TIE
1.5x8x500mm

① ② ③

DOUBLE-SIDED
40x160mm

Fuel Tank
1500cc

UP

● Completed

12 Elevator Pushrod

L/R

PM4x50mm Screw — 2

M4 Nylon Insert Lock Nut — 2

M2x8mm PL4120250

M2 Nut

N.I.

Heavy Duty Horn Bracket

M2 Nylon Insert Lock Nut

M4 Nylon Insert Lock Nut

Heavy Duty Clevis

M2x10mm

PM4x50mm Elevator Pushrod

PA1.7x8mm

● Bottom View

13 Rudder Pushrod

PM4x50mm Screw — 1

M4 Nylon Insert Lock Nut — 1

M2x8mm PL4120250

M2 Nut

N.I.

M4 Nylon Insert Lock Nut

PM4x50mm

PA1.7x8mm

Heavy Duty Clevis

Heavy Duty Horn Bracket

M2 Nylon Insrt Lock Nut

Pushrod

M2x10mm

● Bottom View

14 Flying Wire

- PM2x18mm Screw — 12
- M2 Nut — 12
- d2xD5mm Washer — 24

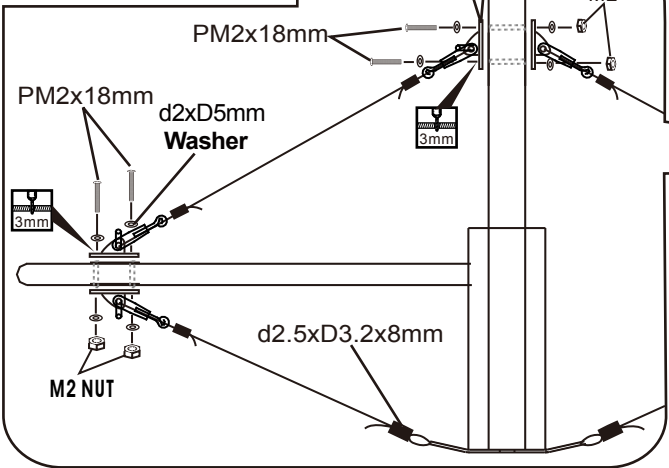

15 Windows

Window A

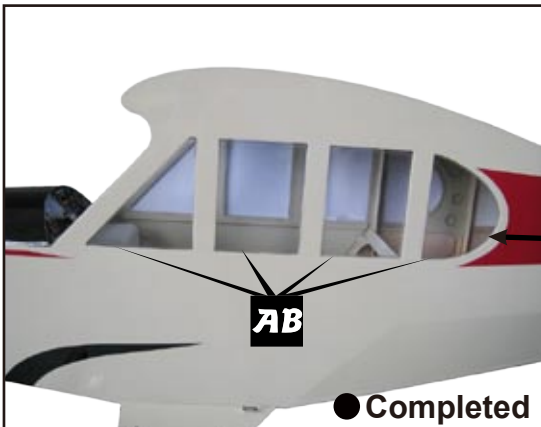

Securely glue the windows to the fuselage.

Window B

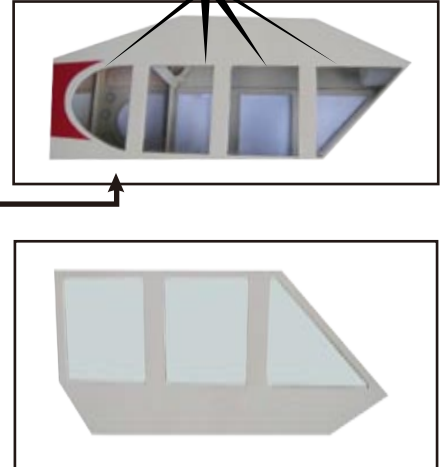

16 Servo Set

- 3x3mm Set Screw — 1
- Linkage Connector — 1
- M2 Nut — 1
- 2mm Washer — 2

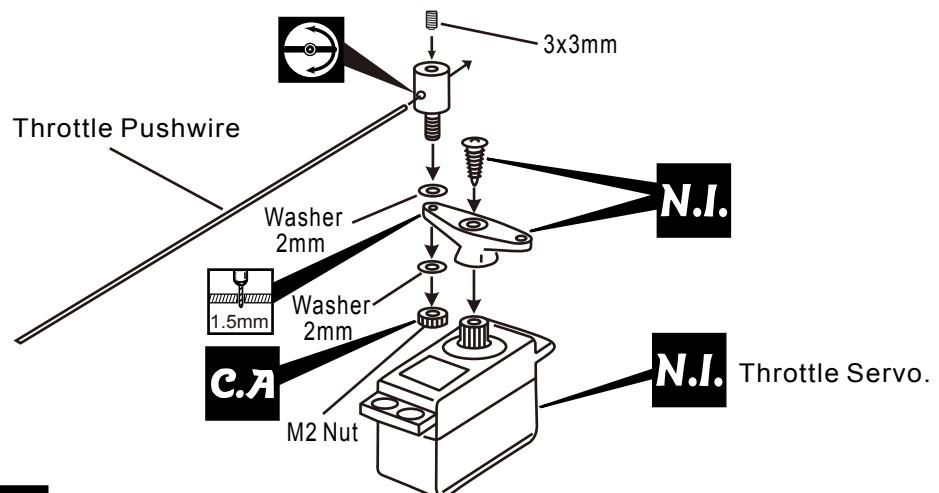

! Please refer to the attached sheet for linkage connector installation.

17 Radio Equipment

● Install and arrange the servo as shown in the diagram.

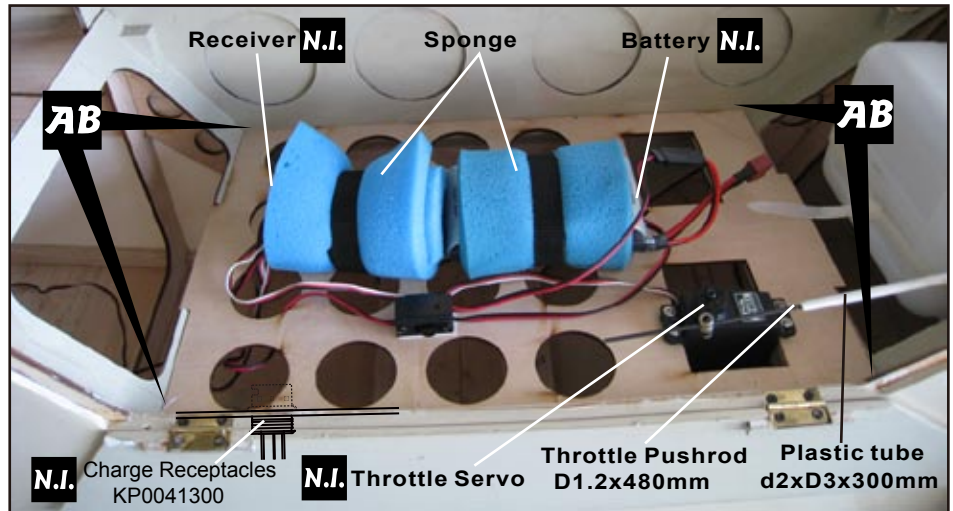
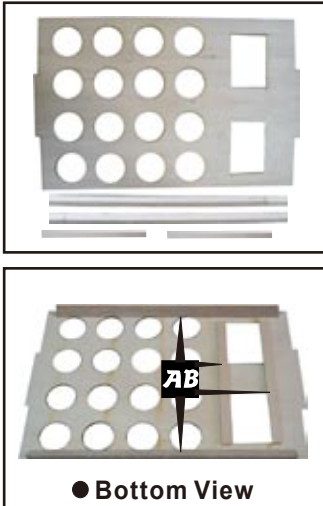

18 Pilot

PWA 2x12mm Screw



PWA2x12mm Screw

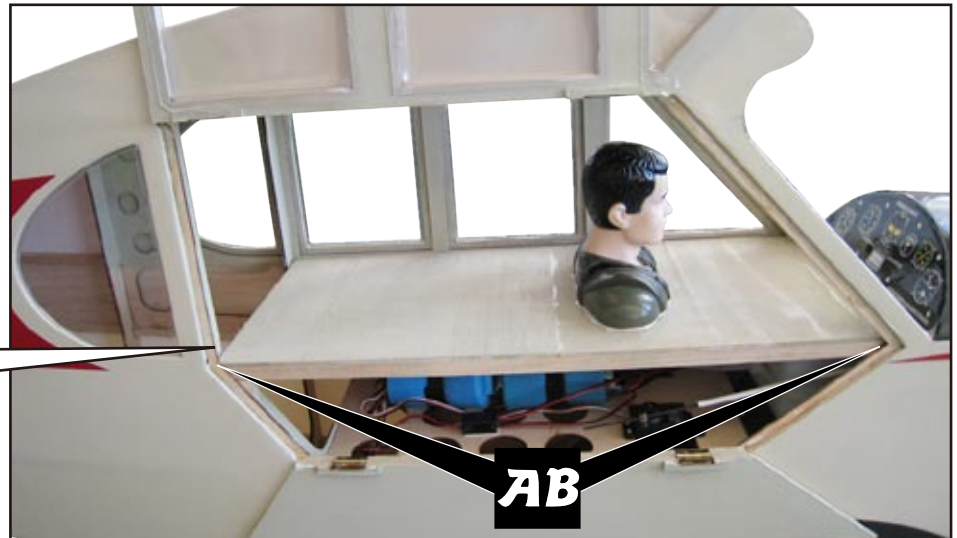
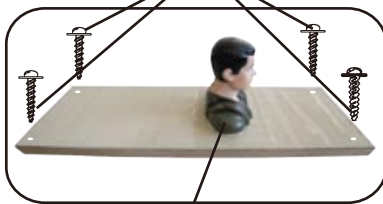

19 Wind Shield

M2 NYLON INSERT LOCK NUT



PM2x14mm Screw



d2 x D5mm Washer

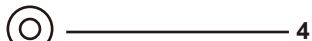

BALSA ROD
Ø8x220mm

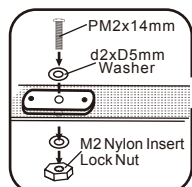

20 Main Wing

HM3x30mm Screw	2
PA3x30mm Screw	2
d3 x D7mm Washer	4

Step 1. Insert the aluminum wing tube with the pre-drilled hole end into the right wing. Align the lines marked at the wing root and wing tube and apply the PM3x30mm machine screw through the pre-drilled hole on top of the wing. (please confirm the alignment of the hole by putting a 2.5mm diameter rod through the pre-drilled wing hole before applying the screw) The hole on the wing tube is pre-threaded, do not over tighten the PM 3mm screw, the set up is for future removal of the wing.

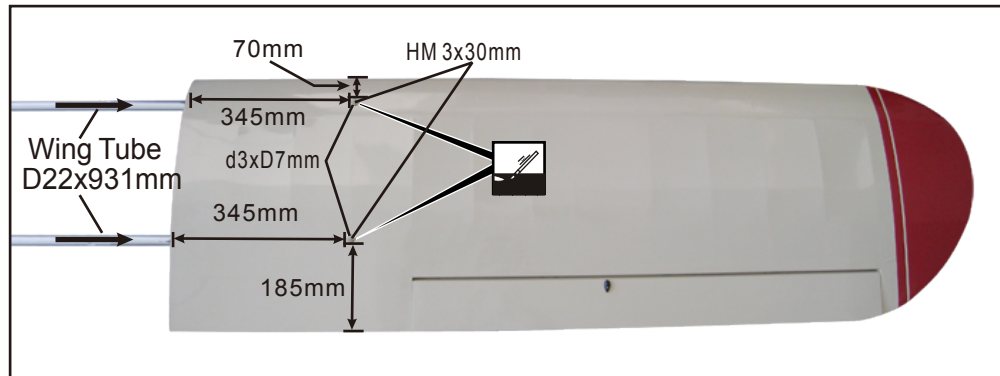

Step 2. Install the right wing to the fuselage by inserting the wing tube (now attached to the right wing) through the fuselage, then install the left wing.

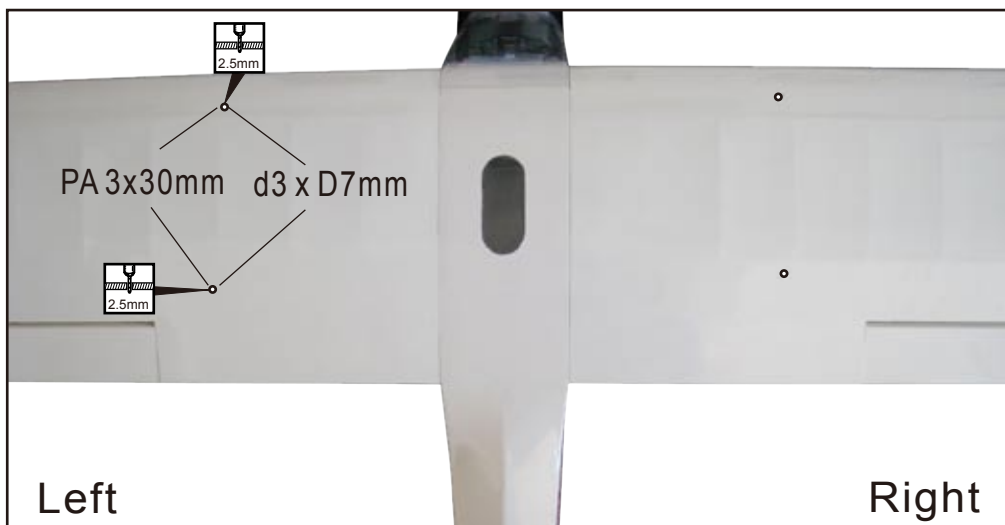
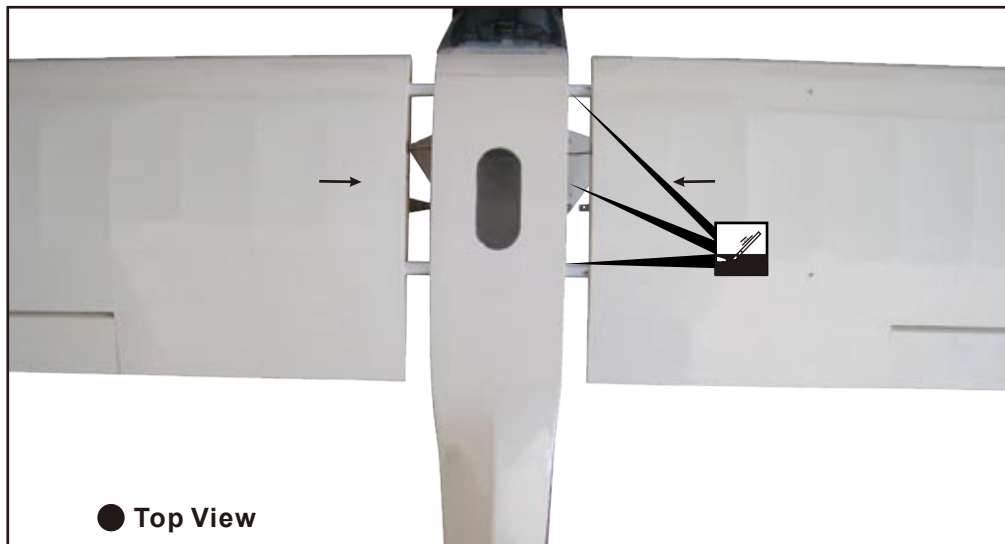

Step 3. Make sure the wings are resting against the fuselage tightly. Locate the pre-drilled 2.5mm hole at top of left wing, and drill along with 2.5mm drill bit until it passes through the wing tube. Apply the PA3x30mm self-tapping screw.

Note : It is recommended that the wing tube stays with the left wing. Removal of the wings could be achieved by removing the right wing machine screw, the right wing then the left wing with wing tube. If removal of wing tube from left wing is also required, it is recommended that instead of applying self-tapping screw in step 3, you pre-tap with M3 thread cutter and apply M3 machine screw.

21 Wing Struts

HM4x15mm Screw



2

d4x D12mm Washer



2

M4 NYLON INSERT LOCK NUT



2

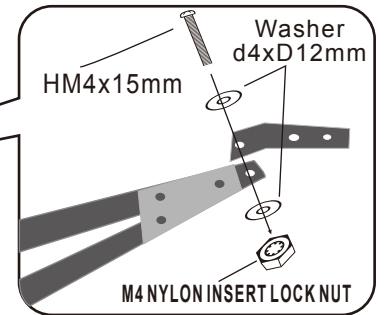

● Bottom View

L/R

22 Wing Setting

- Adjust the wing and fuselage configuration as shown in the diagrams.

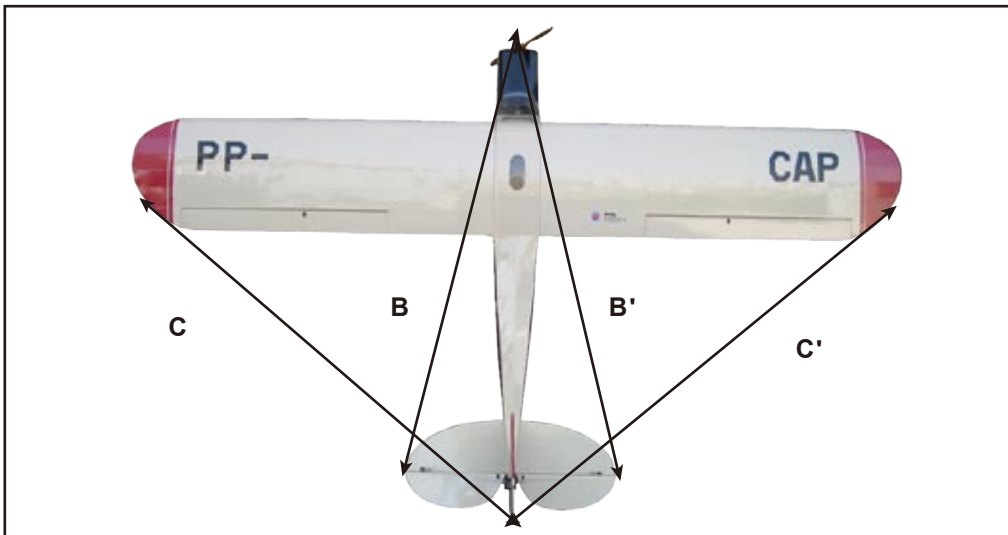

A = A'
B = B'
C = C'

23 Control Throws

Adjust the control throws as shown in the diagram. These throws are good for general flying. You can adjust according to your personal preference.

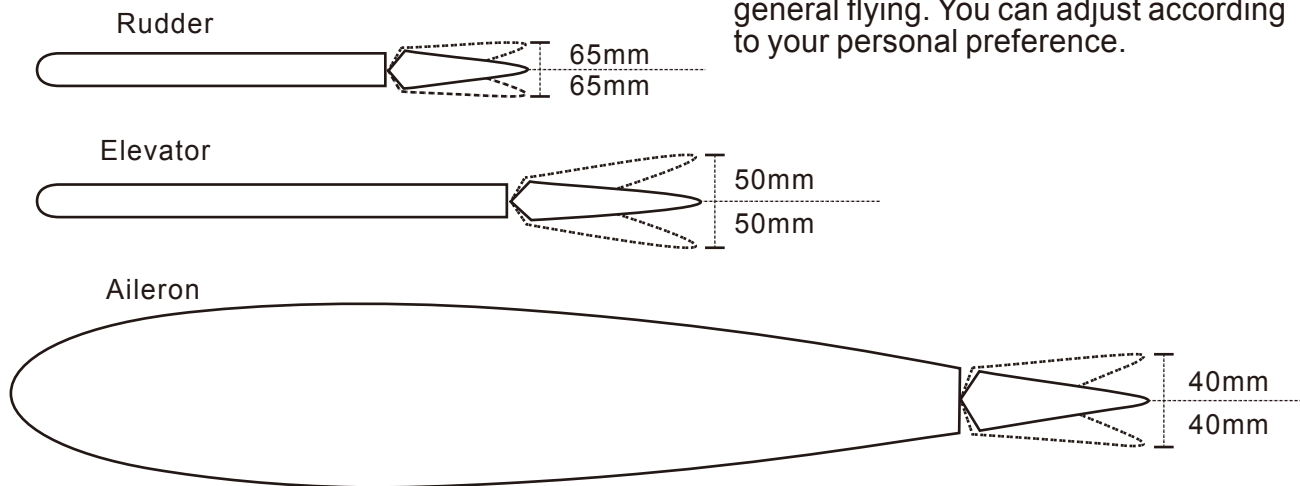

24 C.G.

The ideal C.G. position is **150mm (5.9in.)** behind the leading edge measured at where the wing meets the fuselage. In order to obtain the C.G. specified, add weight to the fuselage or move the battery position. Check the C.G. before flying.

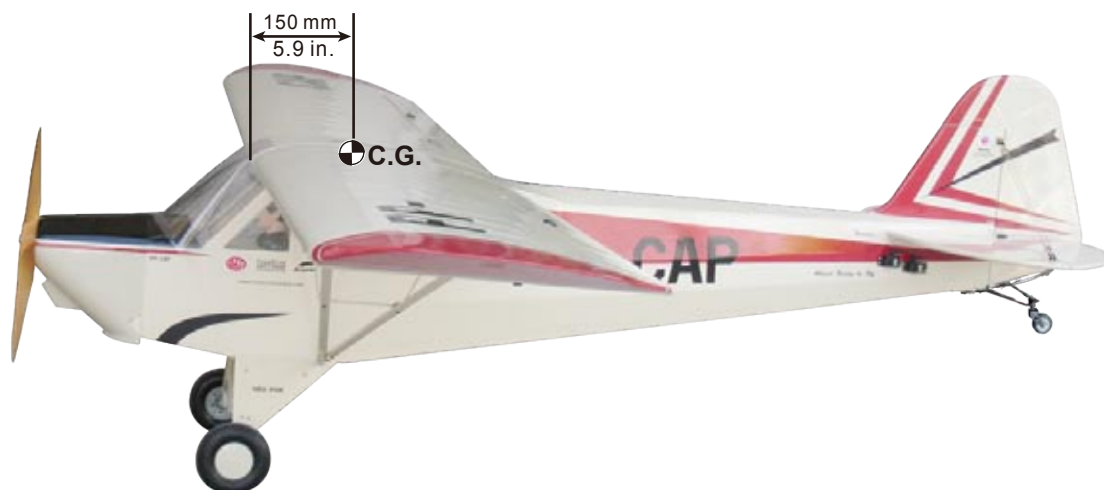

! Warning!

Important Safety Precautions

- # First time flyer should never fly by himself / herself. Assistance from experienced flyer is absolutely necessary.
- # Pre-flight adjustment must be done before flying, it is very dangerous to fly a badly pre-adjusted aircraft.
- # **1/3 PAULISTINHA P-56** is specially designed to be powered by **80c.c.** engine, using a more powerful engine does not mean better performance. In fact, over powered engine may cause structural damage and injuries.
- # Make sure the air field is spacious, never fly the plane too close to people and never get too close to a running propeller.
- # If you find wrinkles on the covering as a result of weather changes, you can use hot iron to remove the wrinkles. Please begin with lower temperature setting and gradually raise the temperature until the wrinkles are gone. Too hot an iron may damage the covering. Don't use hot iron near the seams or edges, hot iron will melt the glue and shrink the covering at the same time, causing the seams to pull away.
- # Check and re-tighten up all factory assembled screws, use thread locker if necessary.

LINKAGE CONNECTOR

HW7111050 & HW7111060

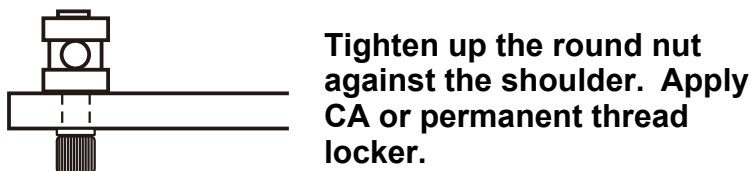
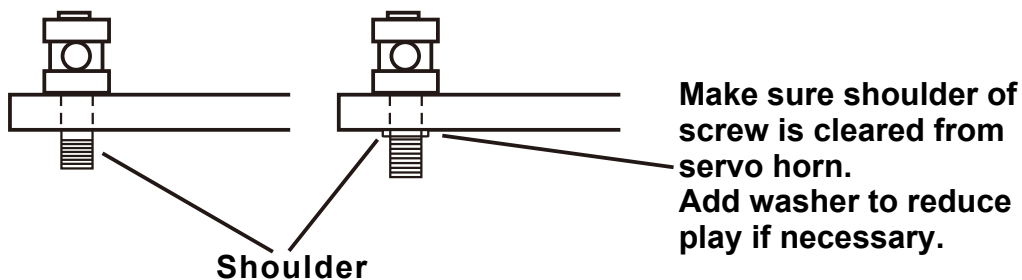
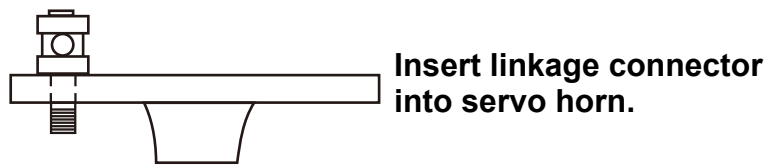
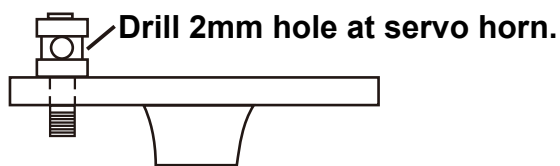

After fastening the round nut, make sure that the linkage connector can rotate freely.

Product Registration Form (US Customers)

We would like to share with you any relevant information regarding your model, including product news and free upgrade parts when applicable. Please fill in the following and send to AirBorne Models, 4749-K, Bennett Drive, Livermore, CA 94551 USA.

1. Name: _____

2. Address: _____

3. Phone #: _____ E-mail: _____

4. Model: _____

Wing QC# _____ Fuselage QC# _____
(QC numbers are stamped on wing and fuselage)

5. Date of Purchase: _____

6. Store Name: _____

Please call AirBorne Models at 925 371 0922 for any assistance in filling this form. Thank you very much for purchasing our product.

Usage of the transparent 3D template

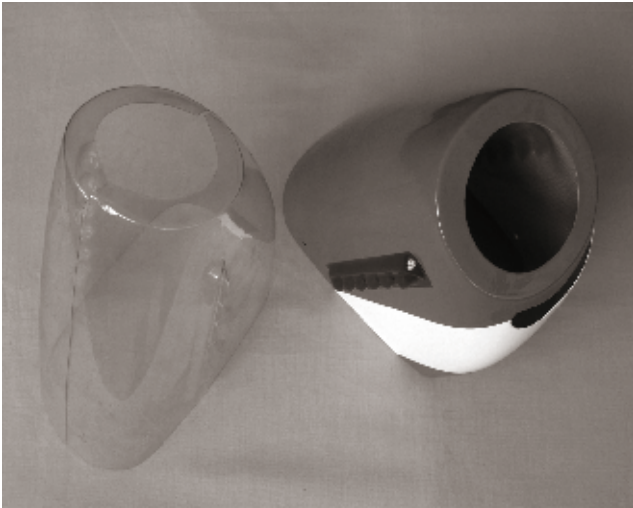

This transparent 3D template is used for position guidance of the actual cutting of the pre-painted cowling.

1

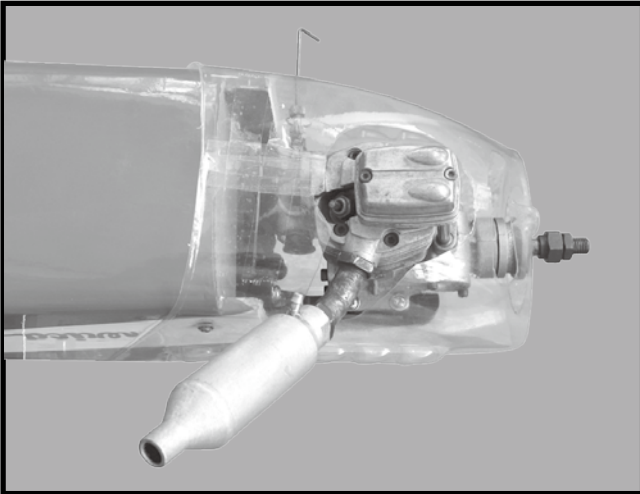

2

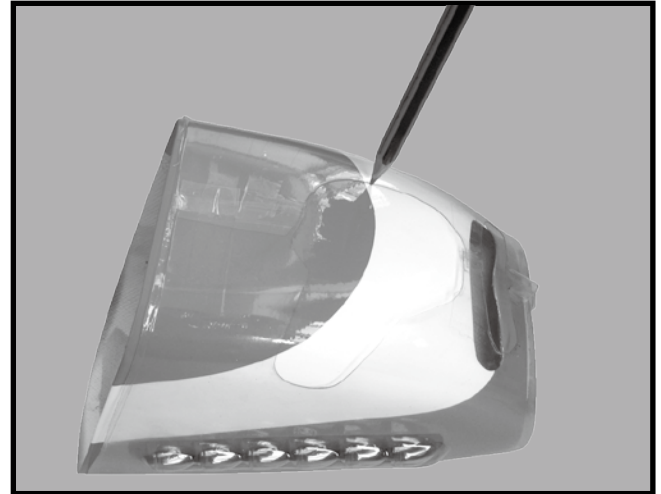

3



4

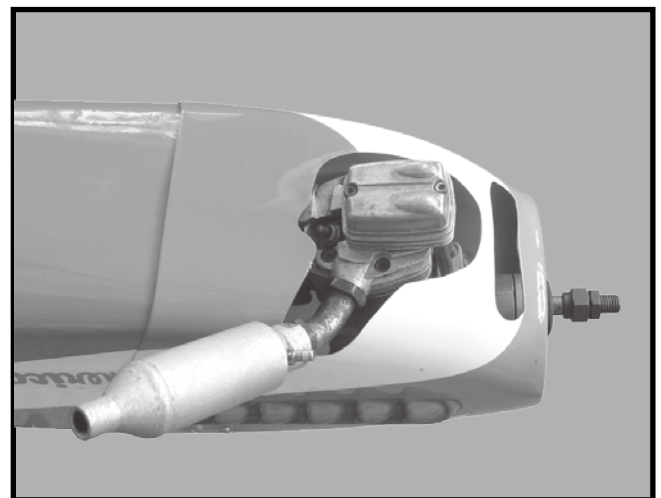

Simply cut the transparent 3D template to fit your engine and exhaust pipe, then slide onto the actual cowling and use as template to mark the openings required for final cutting.

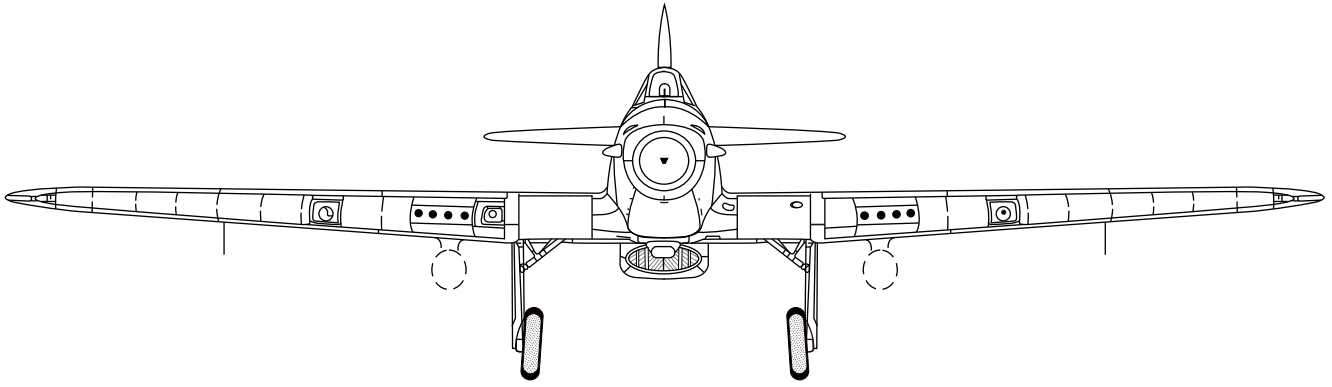

Ducted Fan

Pattern

Warbirds

Funfly

Scale

Electric

Sports

Glider

Trainer

Boat

Accessories

Covering

(Lightex / Toughlon)



**The World Models
Manufacturing Co., LTD.**
www.theworldmodels.com