

AT-6 TEXAN



0.91-1.10 cu. in. displacement 4-stroke
Requires: 6-channel radio w/ 6 standard servos

Specifications

Wing Span	72 in / 1830 mm
Wing Area	777 sq in / 50.1 sq dm
Flying Weight	8.4 lbs / 3800 g
Fuselage Length	51.5 in / 1310 mm

* Specifications are subject to change without notice.*

Warning! This model is not a toy.

It is designed for maximum performance. Please seek advice if one is not familiar with this kind of engine powered precision model. Operating this model without prior preparation may cause injuries. Remember, safety is the most important thing. Always keep this instruction manual at hand for quick reference.



The World Models
 Manufacturing Co., Ltd.
www.theworldmodels.com

FACTORY PRE-FABRICATED
 ALMOST-READY-TO-FLY (ARF) SERIES
 MADE IN CHINA

AT-6 TEXAN

INDEX

BEFORE YOU BEGIN	P. 1
PARTS LIST	P. 2
ASSEMBLY.....	P. 3-12
SAFETY PRECAUTIONS	P.13

BEFORE YOU BEGIN

- 1 Read through the manual before you begin, so you will have an overall idea of what to do.
- 2 Check all parts. If you find any defective or missing parts contact your local dealer. Please DRY FIT and check for defects for all parts that will require CA or Epoxy for final assembly. Any parts you find to be defective after the gluing process may be difficult to remove for warranty replacement. The manufacturer will replace any defective parts, but will not extend to the parts that are good before gluing to defective parts during assembly. Warranty will not cover any parts modified by customer.
- 3 Symbols used throughout this instruction manual comprise of the following : -



Apply epoxy glue.



Apply instant glue
(C.A.glue, super glue.)



Apply thread locker



Must be purchased separately!



Assemble left and right
sides the same way.



Ensure smooth non-binding
movement while assembling.



Peel off shaded portion
covering film.



Cut off shaded portion.



Drill holes with the specified
diameter (here: 3mm).



Pierce the shaded portion
covering film.



Pay close attention here!



Do not overlook this symbol!



Parts List

1. MAIN WING -- 1 set
 2. RETRACTABLE LANDING GEAR LG4404502 -- 1 pair
RETRACTABLE LANDING GEAR COVER -- 1 pair
SCREW PM2x8mm -- 8 pcs
M2 NUT -- 8 pcs
WASHER d2xD5mm -- 16 pcs
180mm Y-CORD Kw0021800 -- 1 pc.
 3. SCREW PB2x25mm -- 6 pcs
SCREW PWA2x8mm -- 8 pcs
PUSHROD Ø1.8x85mm w/ Threads (For Aileron Servos) -- 2 pcs
TRI-HORN M3x14mm (L) (For Aileron) PL4111185 -- 2 sets
SERVO MOUNTING PANEL 2mm (For Aileron Servos) -- 1 pair
CLEVIS PL4112103 -- 2 pcs
STRAPER PL4112102 -- 2 pcs
FUEL TUBE Ø6x5mm -- 4 pcs
 4. WIRE Ø1.8x75mm (For Flxing flap) -- 2 pcs
 5. SCREW PB2x15mm -- 3 pcs
PUSHROD Ø1.8x100mm w/ Threads (For Flap Servo) -- 1 pc.
TRI-HORN M3x14mm (L) (For Flap) PL4111185 -- 1 set
CLEVIS PL4112103 -- 1 pc.
STRAPER PL4112102 -- 1 pc.
FUEL TUBE Ø6x5mm -- 2 pcs
 6. STABILIZER & ELEVATOR -- 1 set
FUSELAGE -- 1 pc.
 7. VERTICAL FIN & RUDDER -- 1 set
 8. TAIL LANDING GEAR PL7100002 -- 1 set
SCREW PA3x12mm -- 2 pcs
COLLAR 2.6mm w/set screw -- 1 set
TAIL WHEEL Ø30mm-- 1 pc.
 9. SCREW PB2x22mm -- 6 pcs
PUSHROD Ø1.8x730mm w/ Threads (For Elevator Servo) -- 2 pcs
TRI-HORN M3x22mm (L) (For Elevator Servo) PL4111251 -- 2 sets
CLEVIS PL4112103 -- 2 pcs
FUEL TUBE Ø6x5mm -- 2 pcs
 10. SCREW PM2.5x35mm -- 3 pcs
PUSHROD Ø1.8x835mm w/ Threads (For Rudder Servo) --1 pc.
TRI-HORN M3x22mm (L) (For Rudder Servo) PL4111251 -- 1 set
CLEVIS PL4112103 -- 1 pc.
FUEL TUBE 6x5mm -- 1 pc.
 11. FUEL TANK 400cc PL1111400N -- 1 set
CABLE TIE (For Fuel Tank) 1.5x5x400mm -- 1 pc.
DOUBLE-SIDED TAPE 40x100mm -- 1 pc.
 12. SOCKET HEAD SCREW M4x25mm-- 4 pcs
WASHER d4xD12mm -- 4 pcs
BLIND NUD M4x15mm -- 4 pcs
ENGINE MOUNT PL51111080 -- 1 set
 13. LINKAGE CONNECTOR 2.1mm HW7111060 -- 1 set
 14. THROTTLE PUSHWIRE Ø1.2x400mm -- 1 pc.
PLASTIC TUBE d2xD3x200mm -- 1 pc.
ENGINE MOUNT ALUMINUM PLATE -- 1 set
ANTI-VIBRATION MOUNT 4C-91 PL5214094 -- 1 set.
INCLUDE: SOCKET HEAD SCREW M4x35mm -- 4 pcs
SCREW KM3x20mm -- 8 pcs
WASHER d4xD12mm -- 8 pcs
NYLON INSERT LOCK NUT M3 -- 8 pcs
NYLON INSERT LOCK NUT M4 -- 4 pcs
 15. FUEL TUBE Ø6x5mm -- 2 pcs
STRAPER PL4112102 -- 2 pcs
SPONGE 10x80x200mm -- 2 pcs
PUSH ROD Ø1.8x75mm (For Elevator) -- 1 pc.
PUSH ROD CONNECTOR (For Elevator) PL4410010 -- 1 set
 16. SOCKET HEAD SCREW M4x55mm -- 2 pcs
WASHER d4xD15mm -- 2 pcs
PLYWOOD 2x25x100mm (Wing Protection) -- 1 pc.
 17. SCREW PWA2.3x8mm -- 6 pcs
SILICON GROMMET d1.5xD6.5mm -- 6 pcs
PILOT PC001085A -- 1 set
CANOPY --1 pc.
 18. SCREW PWA2.6x12mm -- 8 pcs
COWLING -- 1 pc.
TRANSPARENT 3D TEMPLATE -- 1 pc.
COWLING BRACKET PL5320010 -- 4 pcs
QUICK RELEASE NYLON RIVET PL1208042 -- 4 pcs
SCREW KA2.3x8mm -- 4 pcs
SPINNER NUT HW2340001 -- 1 set
CARB INTAKE -- 1 set
OIL COOLER INTAKE -- 1 set
 19. DECALS: A212DEC -- 1 set
- **COVERING:--**
TOUGHLON STL 201 BLACK
TOUGHLON STL 331 CUB YELLOW

1 Main Wing

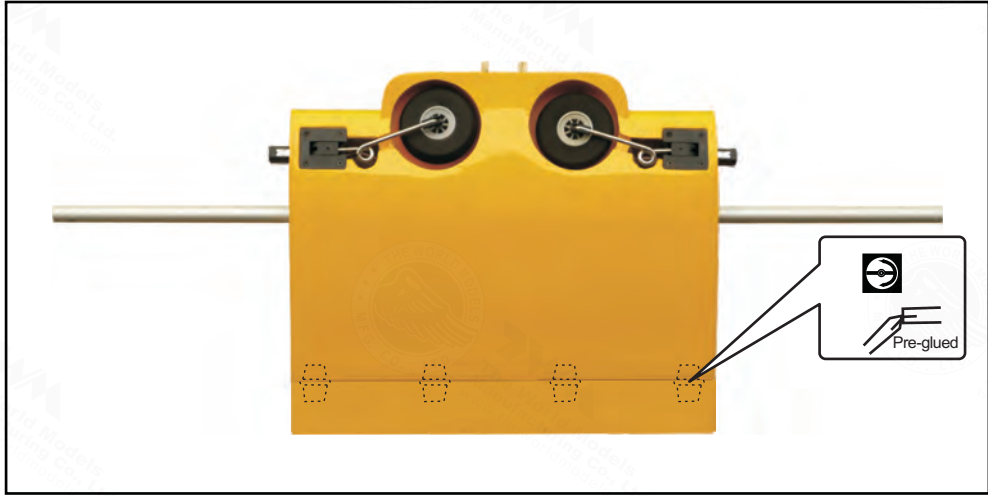

● Bottom View

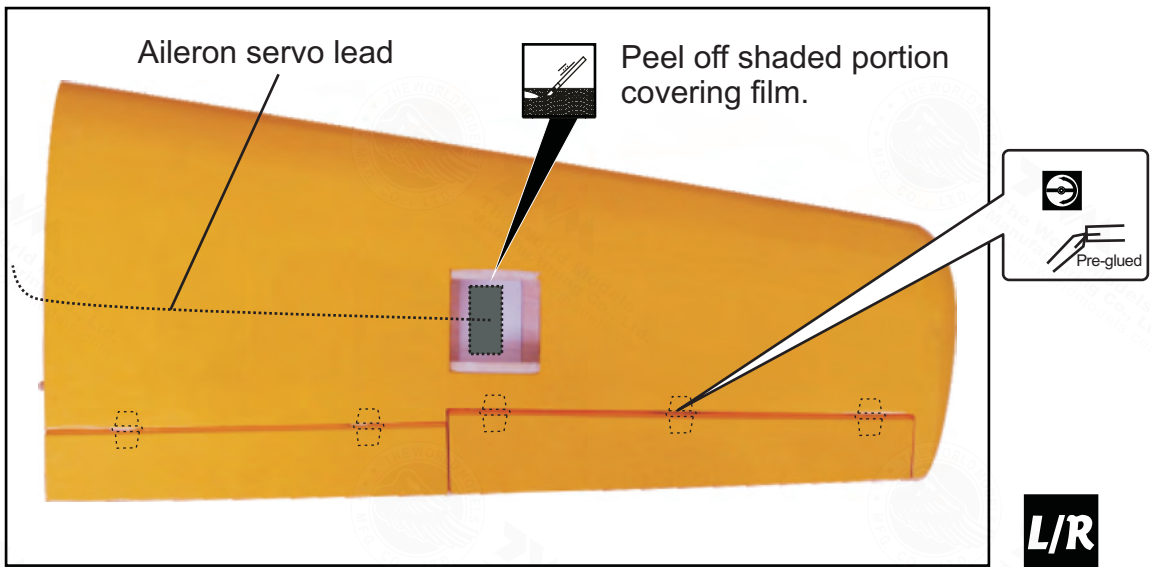

● Bottom View

L/R

2 Main Retractable Landing Gear

- PM2x8mm Screw — 8
- M2 Nut — 8
- d2xD5mm Washer — 16

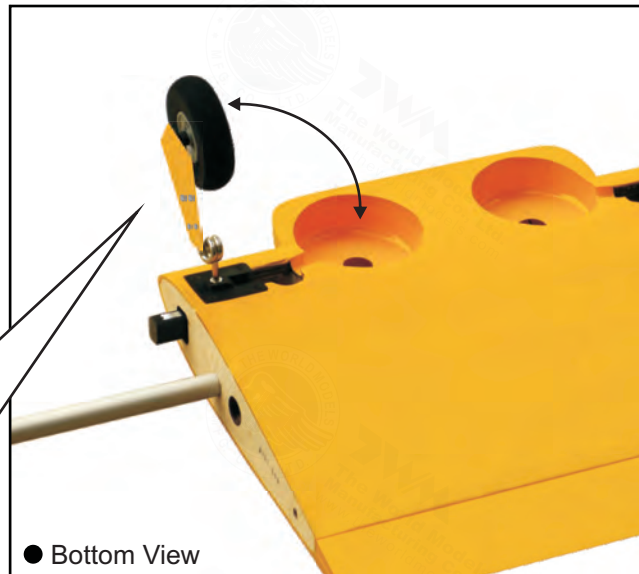
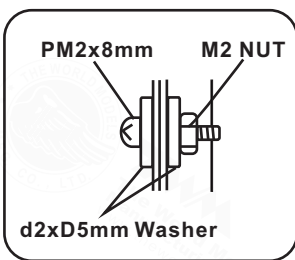

● Bottom View



Completed

L/R

3 Aileron Servo

- Ø1mm pilot holes for World Models tri-horn are pre-drilled. Please look for pin-hole marks at under side of control surfaces.

PB2x25mm Screw



PWA2x8mm Screw

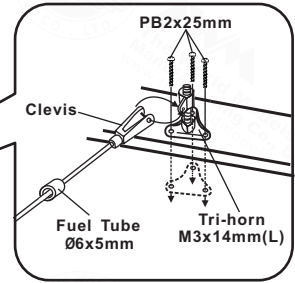
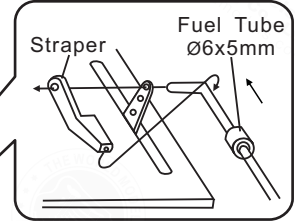
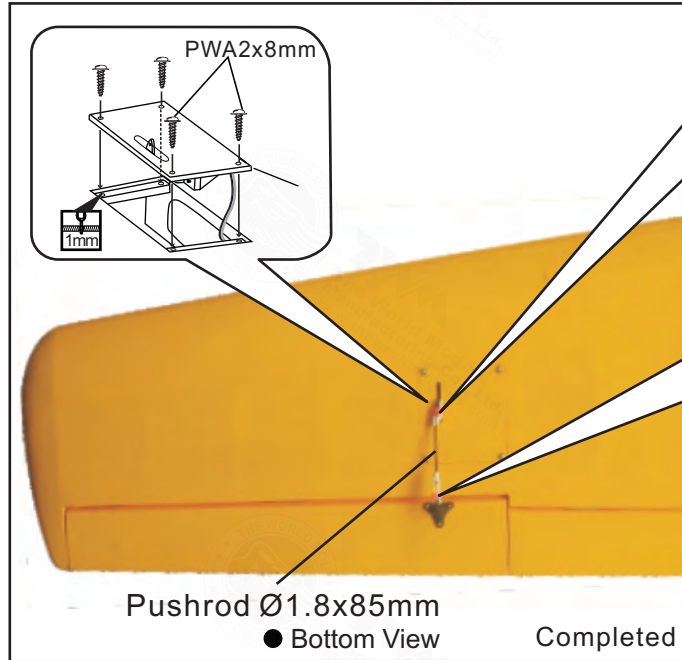
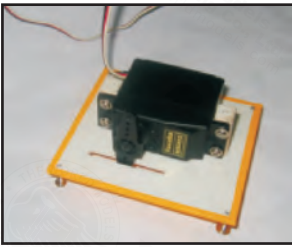
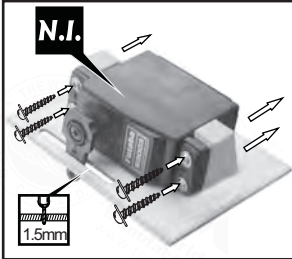
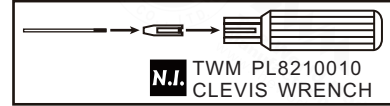

Pushrod Ø1.8x85mm

● Bottom View

Completed



4 Main Wing

- Apply glue to both sides of all surfaces in contact. Use a stick to apply glue to inner side of wing joiner sleeve, and apply glue to wing joiner before putting them together. Wing joiner not glued properly will lead to wing failure and plane crash.

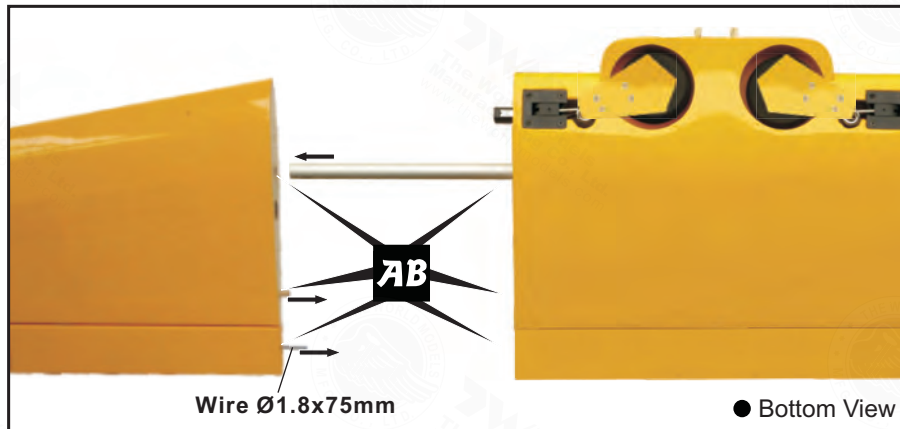

Wire Ø1.8x75mm

● Bottom View



Completed

● Bottom View



5 Flap Servo

- $\varnothing 1\text{mm}$ pilot holes for World Models tri-horn are pre-drilled. Please look for pin-hole marks at under side of control surfaces.

PB2x15mm Screw



Lead to Aileron servo

Lead to Retractable

Lead to Flap servo

- Select the servo horn that will give 26mm travel when rotates through 180° .

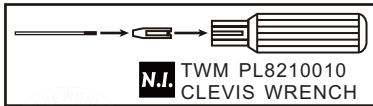
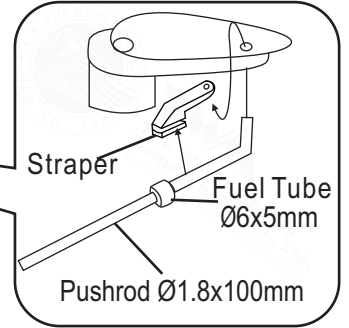
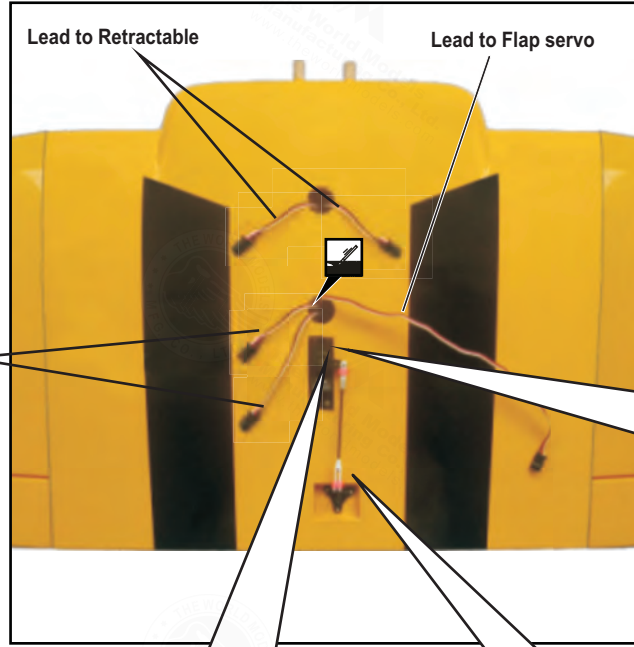

TWM PL8210010
CLEVIS WRENCH

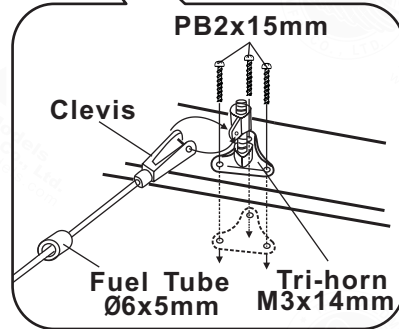
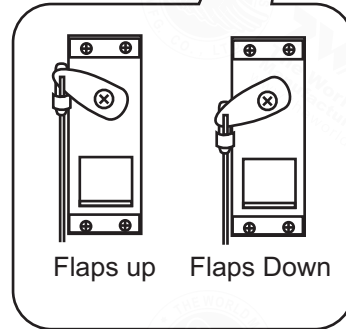

6 Stabilizer & Elevator

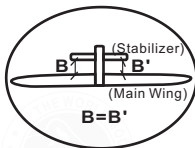

Temporary install the main wing, adjust leveling of the stabilizer to make it as parallel to the main wing as possible.

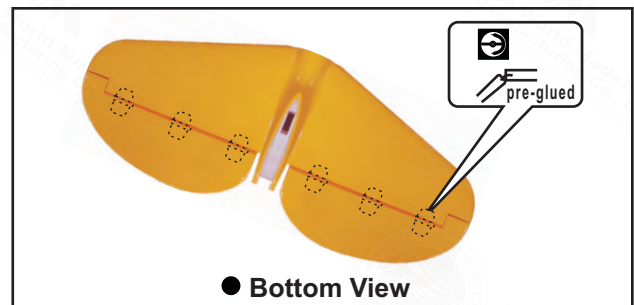
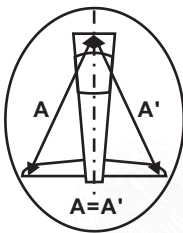

● Bottom View

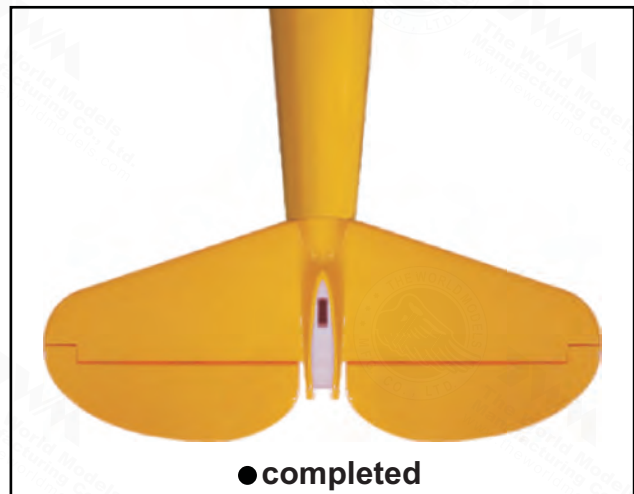
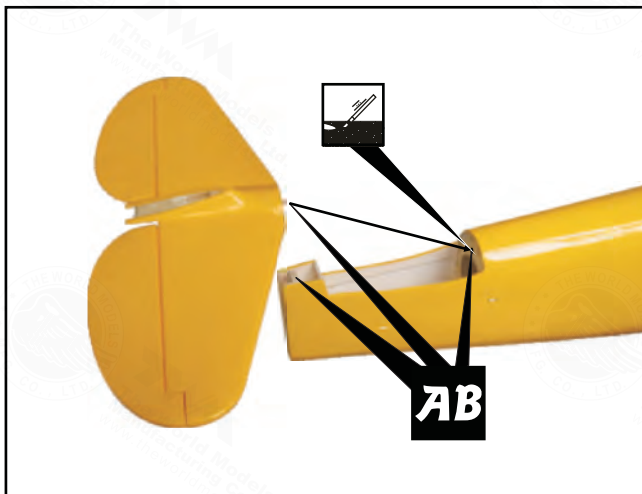

● completed

7 Vertical Fin & Rudder

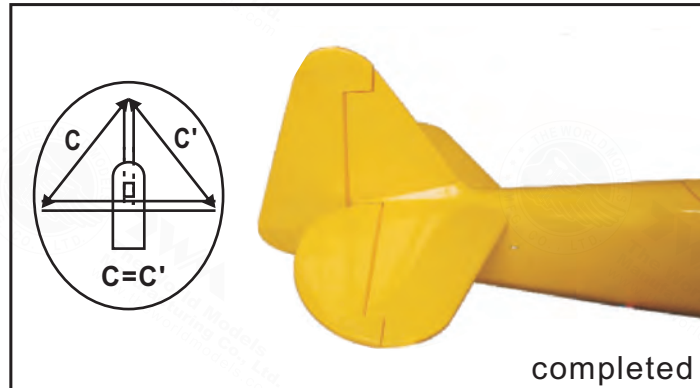
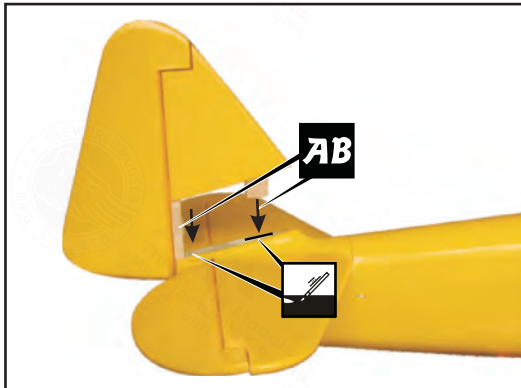
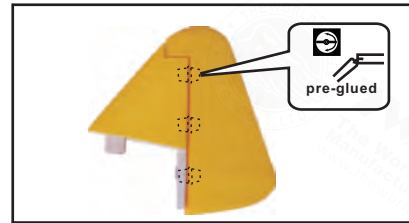

8 Tail Landing Gear

PA3x12mm Screw



2.6mm Collar

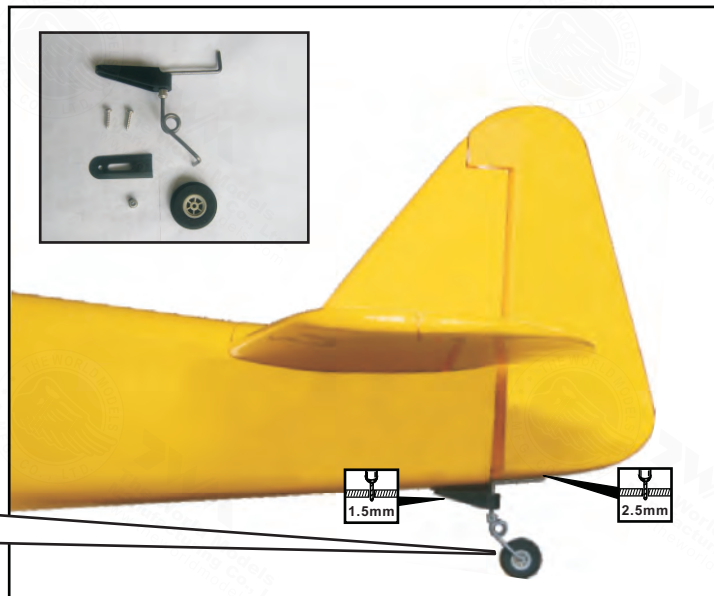
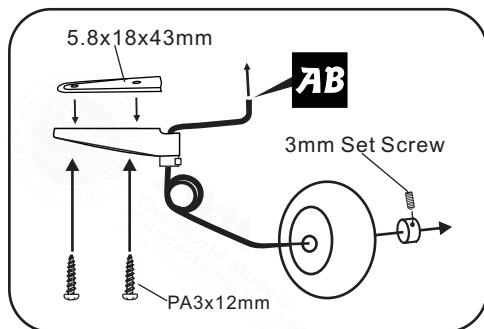
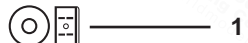

9 Elevator Pushrod

PB2x22mm Screw



- Ø1mm pilot holes for World Models tri-horn are pre-drilled. Please look for pin-hole marks at under side of control surfaces.

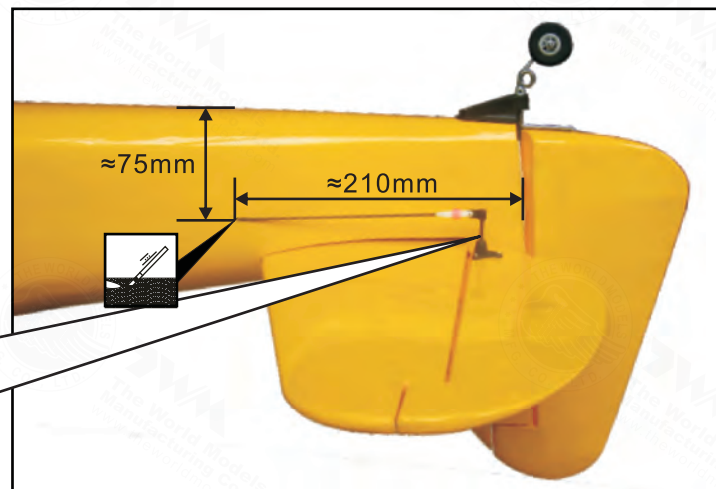
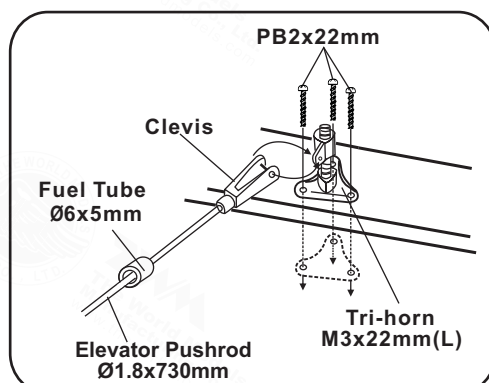
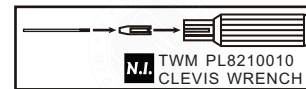

L/R

10 Rudder Pushrod

● Ø1mm pilot holes for World Models tri-horn are pre-drilled. Please look for pin-hole marks at side of control surfaces.

PM2.5x35mm Screw

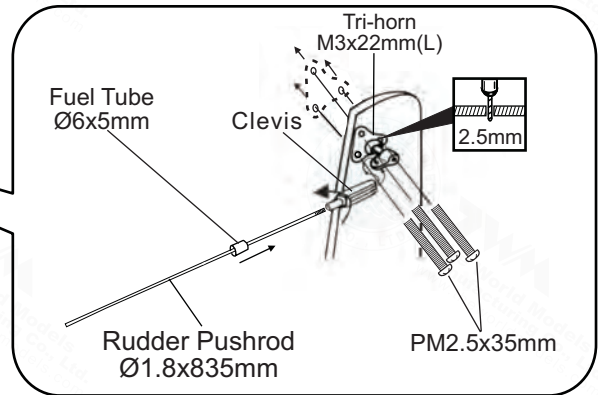
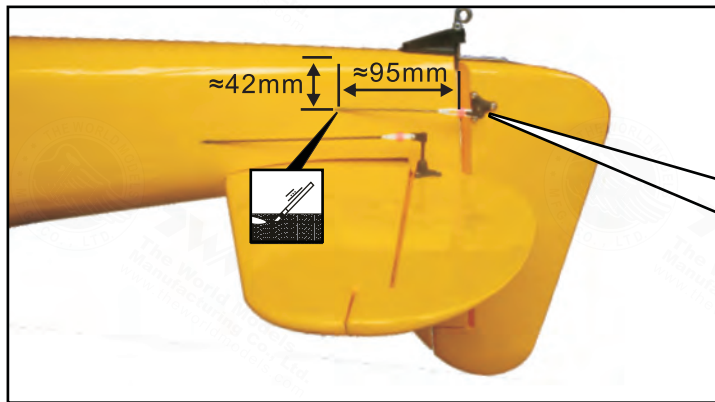
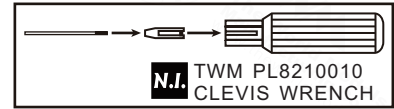

11 Fuel Tank

DOUBLE-SIDED TAPE 40x100mm

CABLE TIE 1.5x5x400mm

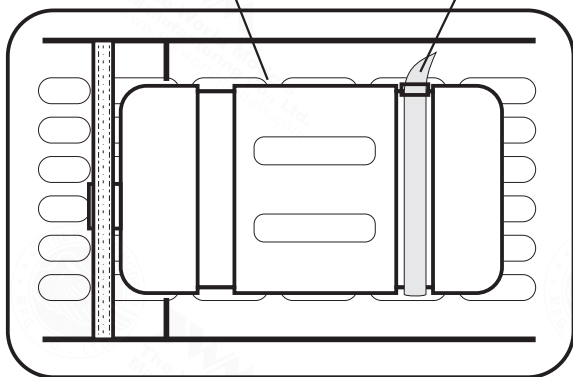

Battery Cover

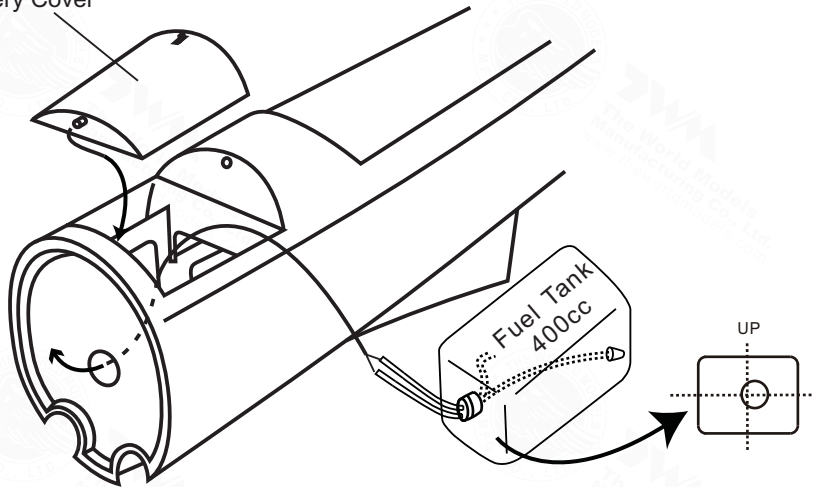

12 Engine Mount

M4x25mm Socket Head Screw



d4xD12mm Washer



M4x15mm Blind Nut



● Apply thread locker to screws.

! Blind nuts are off-centered to keep the spinner at the fuselage axis.

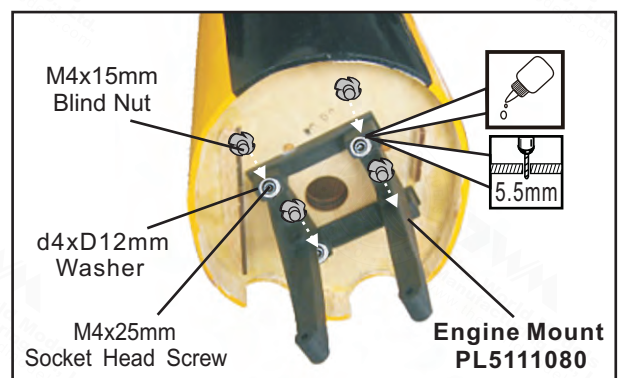

A: Inverted mount

B: Inclined mount

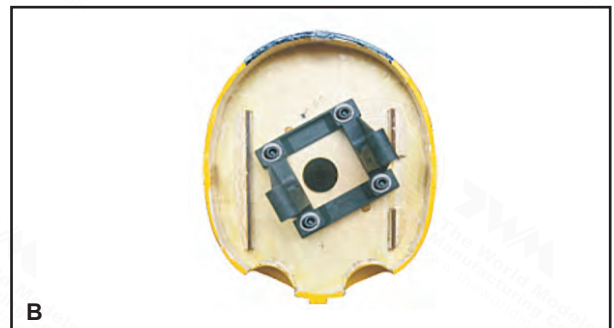
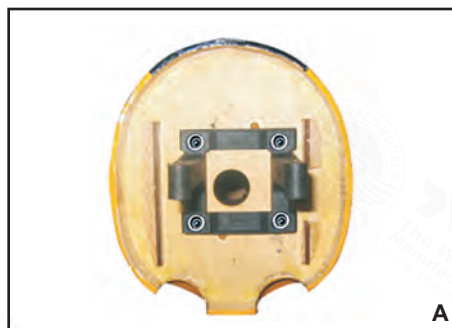

13 Servo Set

	3 x 3mm Set Screw	1
	Linkage Connector	1
	M2 Nut	1
	2mm Washer	2

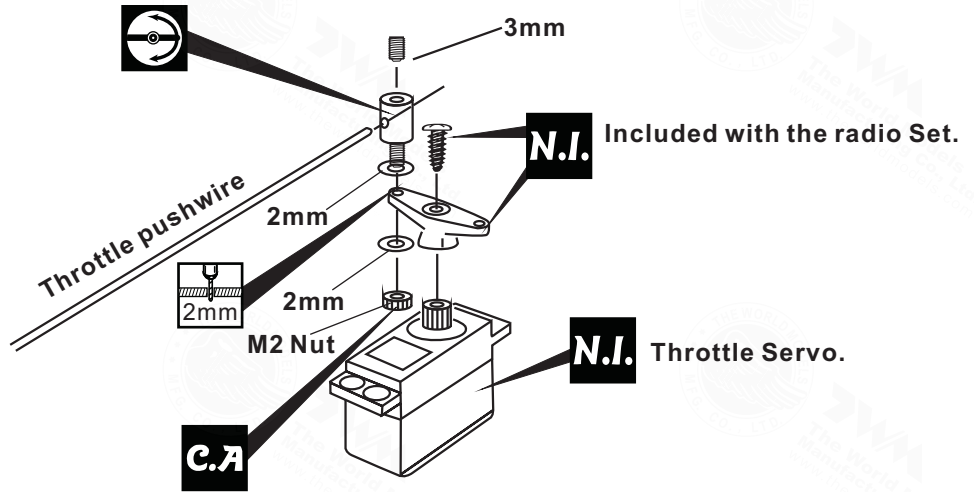

! Please refer to attached sheet for linkage connector installation.

14 Engine

	M4x35mm Socket Head Screw	4
	KM3x20mm Screw	8
	M4 Nylon Insert Lock Nut	4
	M3 Nylon Insert Lock Nut	8
	d4xD12mm Washer	8

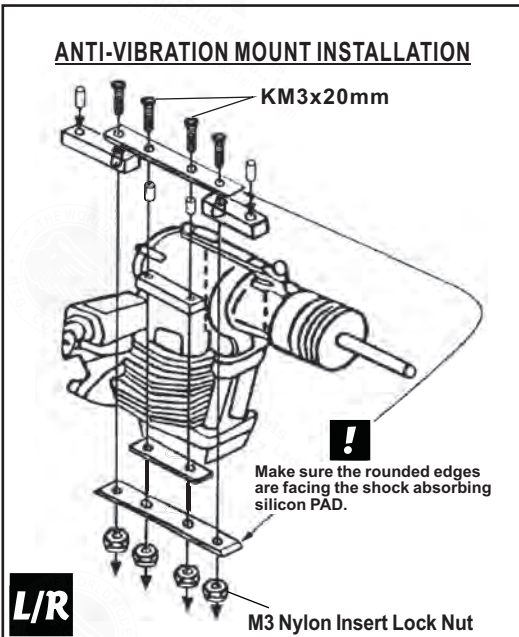
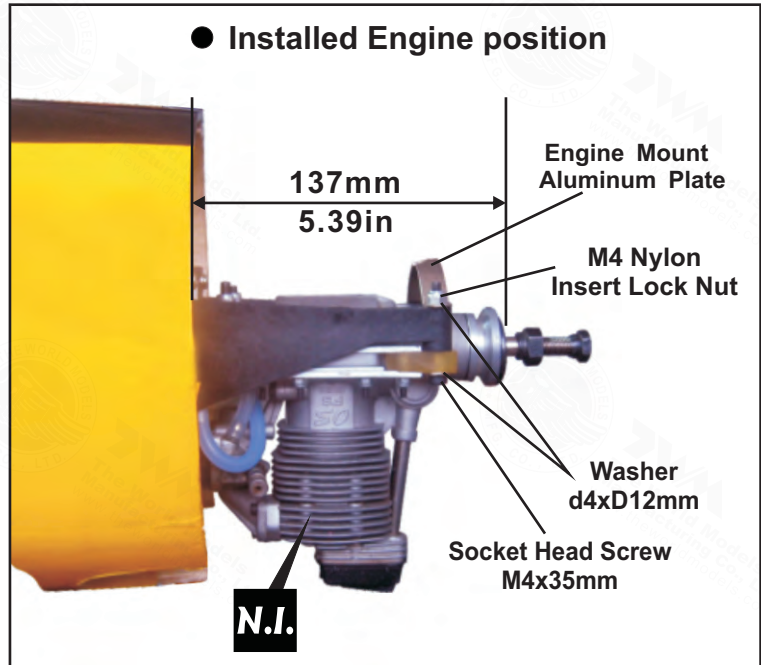

! Illustration is for inverted mounting. You can mount the engine upright or sideways simply by rotating the engine mount. Thrust angles will not be affected.

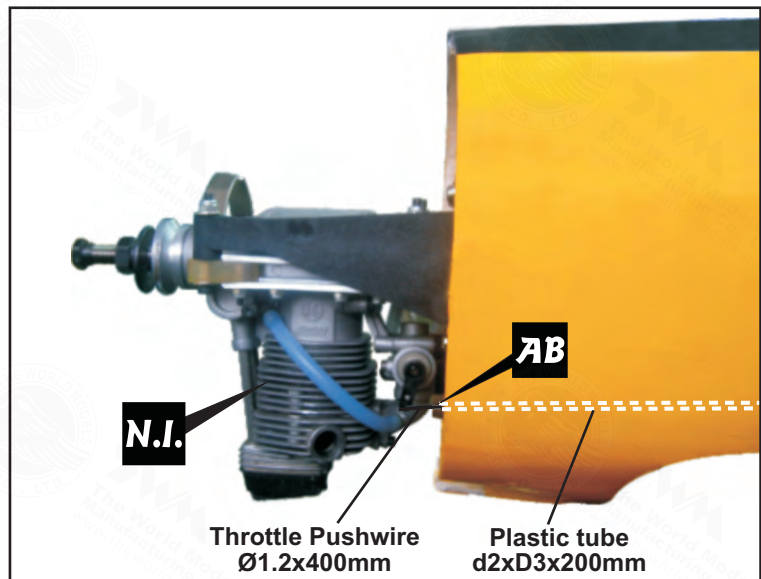

15 Radio Equipment

● Install and arrange the servos as shown in the diagram.

Labels in the main diagram include: Plastic tube d2xD3x200mm, Rudder Servo **N.I.**, Throttle Pushwire Ø1.2x400mm, Throttle Servo **N.I.**, Fuel Tube Ø6 x 5mm, Receiver, Elevator Servo **N.I.**, Battery, Charge Receptacles, and Sponge.

Bottom View sub-diagrams include:

- J1 (Pushrod Ø1.8x75mm) and J2 (Pushrod Ø1.8x730mm) diagrams showing servo horn connections.
- Elevator Pushrod Ø1.8x75mm assembly with M2 Nut and KM2x8mm screw.
- Pushrod Connector and Elevator Servo connection diagram.

16 Main Wing

- M4x55mm Socket Head Screw — 2
- d4xD15mm Washer — 2

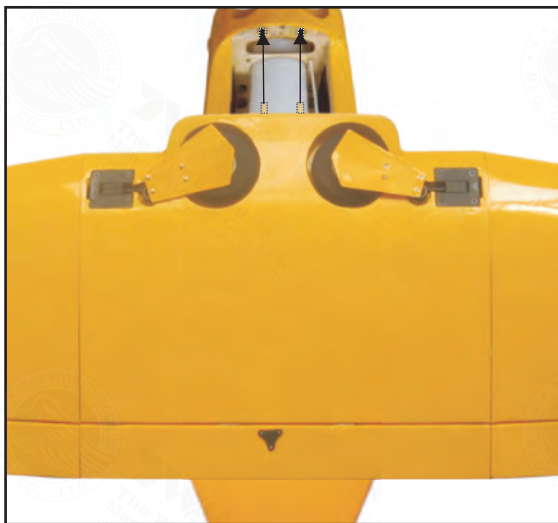

● Bottom View

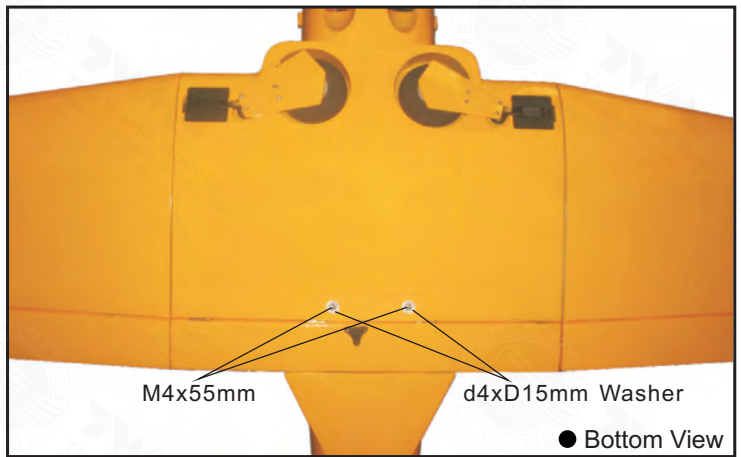

● Bottom View

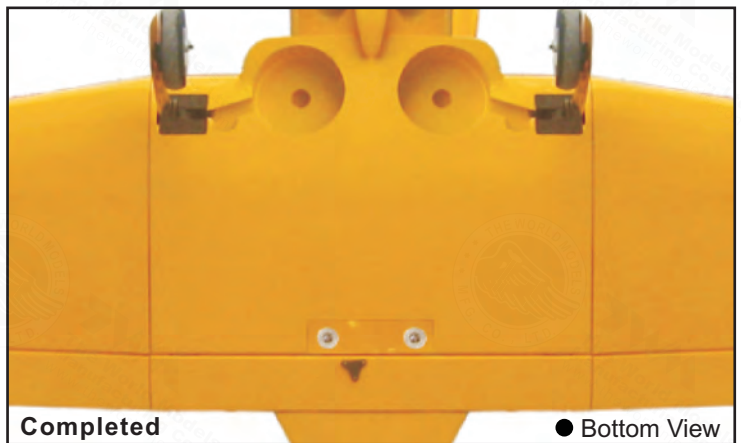

Completed

● Bottom View

17 Canopy

● First insert the grommet to the canopy then apply screw.

- PWA2.3x8mm Screw — 6
- d1.5xD6.5mm Silicon Grommet — 6

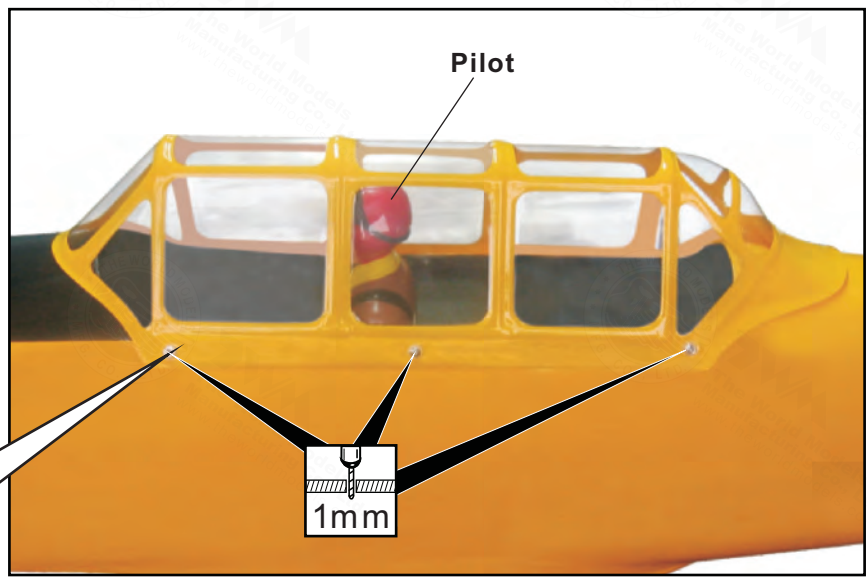
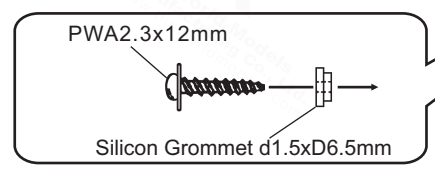
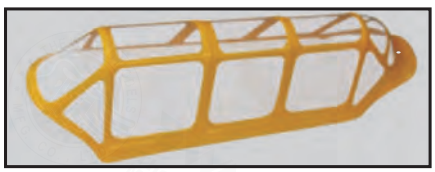

18 Cowling

● Please refer to the attached sheet for usage of the transparent 3D template.

- PWA2.6x12mm Screw — 8
- KA2.3x8mm Screw — 4

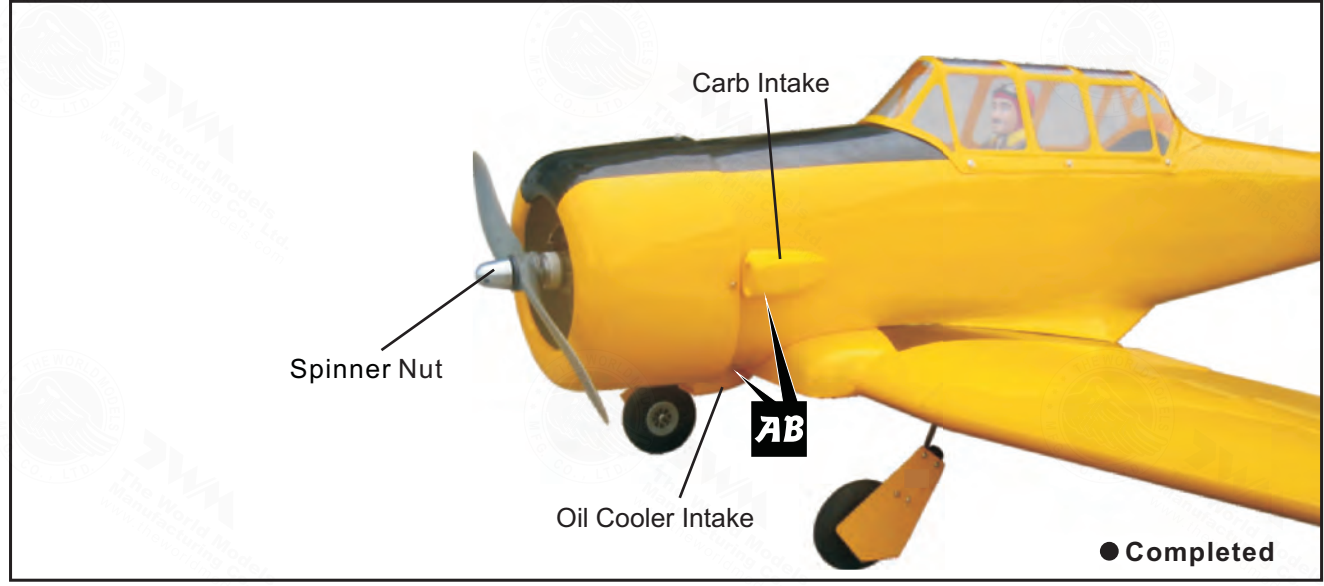
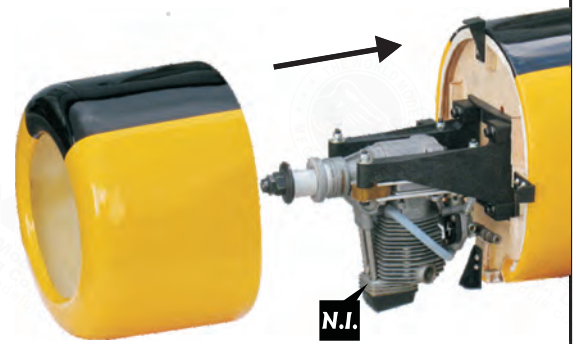
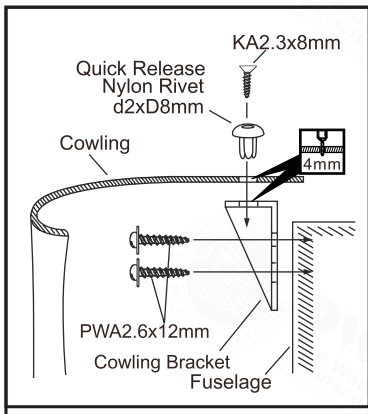
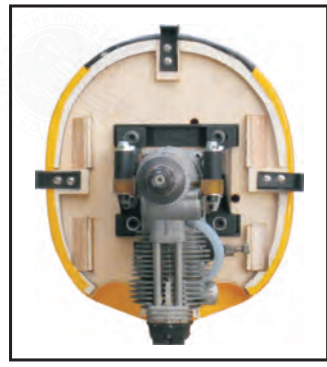

19 Wing Setting

- Adjust the wing and fuselage configuration as shown in the diagrams.

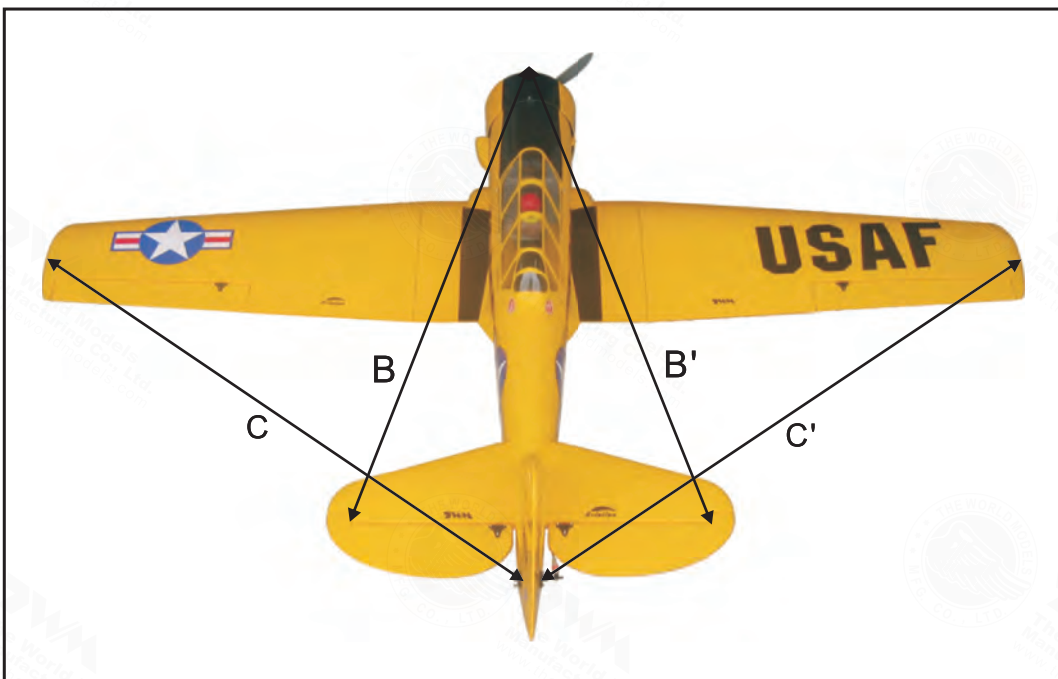
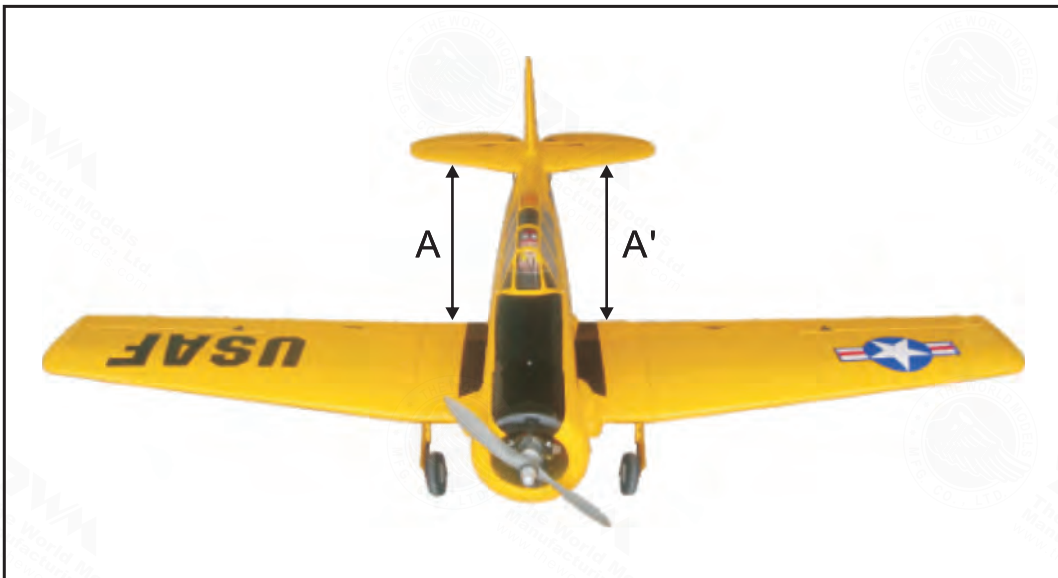

$$A = A' \quad B = B' \quad C = C'$$

20 Control Throws

Adjust the control throws as shown in the diagram. These throws are good for general flying. You can adjust according to your personal preference.

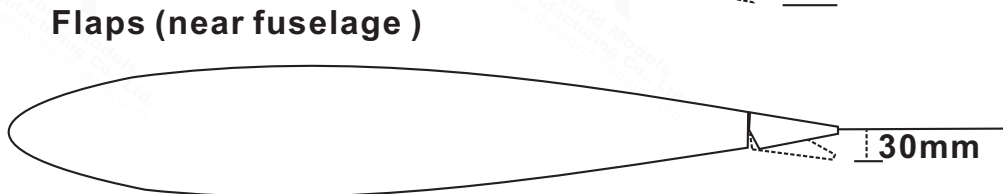
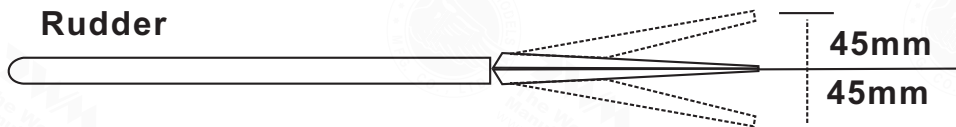
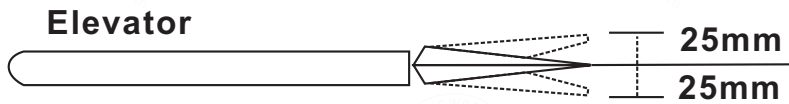

21 C. G.

The ideal C. G. position is 135 mm (5.3 in) behind the leading edge measured at where the wing meets the fuselage. In order to obtain the C. G. specified, add weight to the fuselage or move the battery position. Check the C. G. before flying.

If you are converting this model to electric, please move the C.G. forward 10% of current C.G. distance from leading edge to compensate for weight of fuel.



- Measure C.G. with the wheels in retracted position

! Warning!

Important Safety Precautions

- # First time flyer should never fly by himself / herself. Assistance from experienced flyer is absolutely necessary.
- # Pre - flight adjustment must be done before flying, it is very dangerous to fly a badly pre - adjusted aircraft.
- # **AT-6 TEXAN** is specially designed to be powered by 0.91-1.10 4-stroke glow engine, using a more powerful engine does not mean better performance. In fact, over powered engine may cause severe damage and injuries.
- # Make sure the air field is spacious, never fly the plane too close to people and never get too close to a running propeller.
- # If you find wrinkles on the covering as a result of weather changes, you can use hot iron to remove the wrinkles. Please begin with lower temperature setting and gradually raise the temperature until the wrinkles are gone. Too hot an iron may damage the covering. Don't use hot iron near the seams or edges, hot iron will melt the glue and shrink the covering at the same time, causing the seams to pull away.
- # Check and re-tighten up all factory assembled screws, use thread locker if necessary.

- # When Flaps are lowered, nose of model will rise. The nose-up varies with the speed at which the models is flying when you lower the flaps and the extent to which they are lowered. Check effect of flaps at higher altitude to avoid surprises during landing. You may apply down trim of the elevator to compensate for the nose-up effect when lowering the flaps. Taking off with flaps lowered is not recommended, as the increased drag may require a longer runway and more engine power for the model to take off.

Should you require to bend the landing gear wire, please insert a round metal bar into the spring ring and apply force there as leverage. Bending the wire directly may damage the mounting block structure.

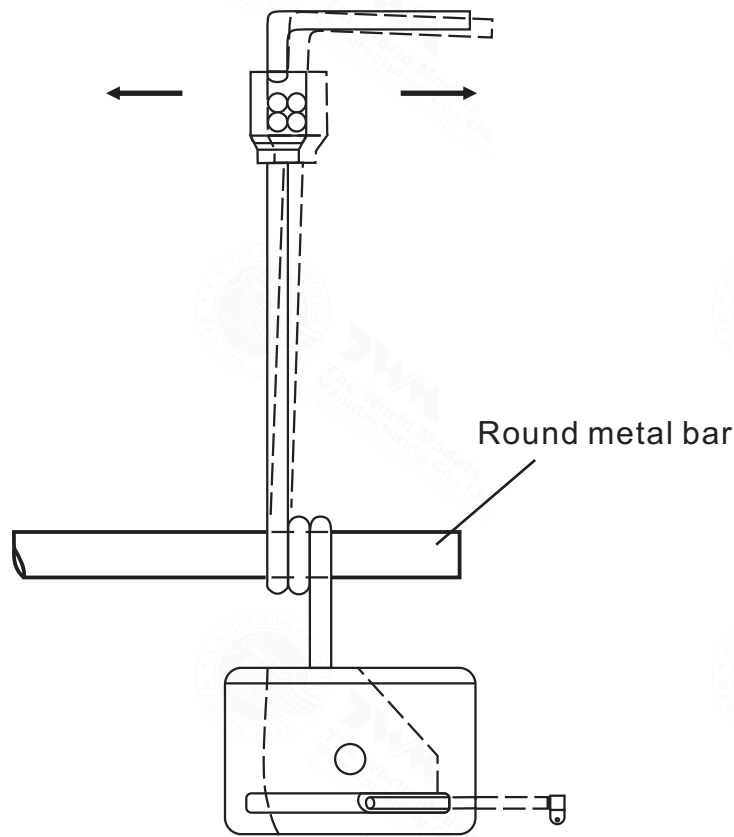

Usage of the transparent 3D template



This transparent 3D template is used for position guidance of the actual cutting of the pre-painted cowling.

1

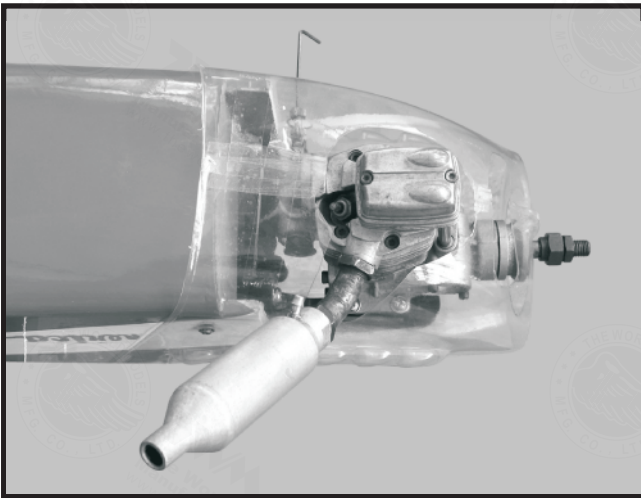

2

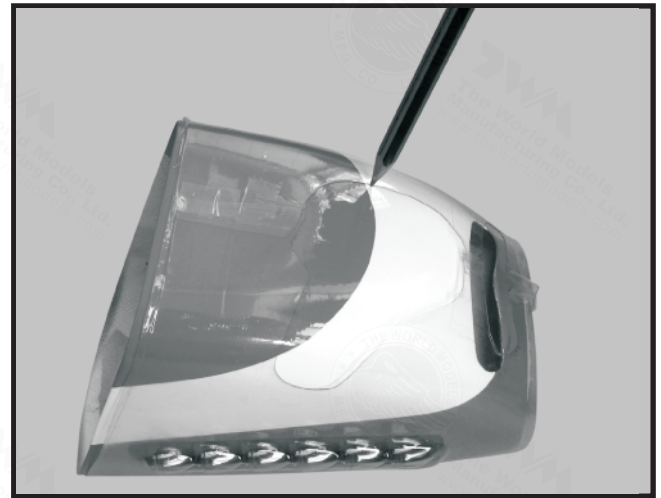

3

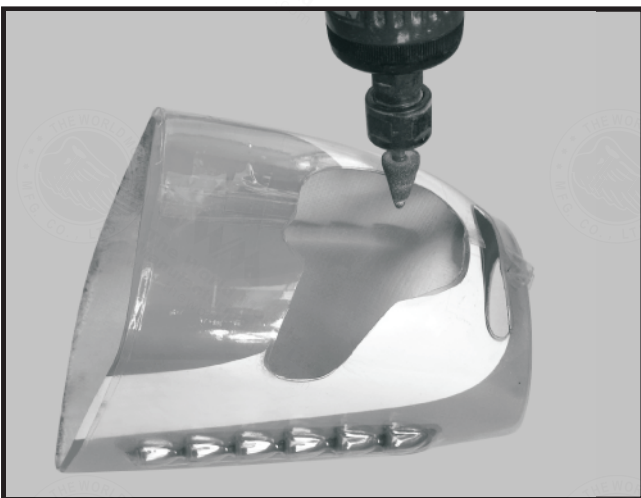

4

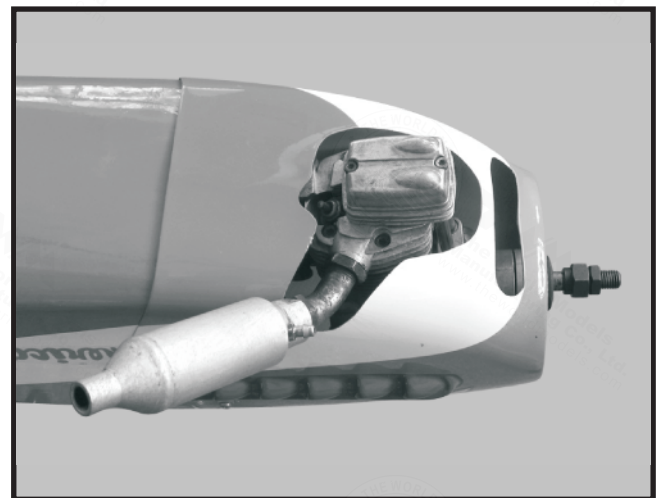

Simply cut the transparent 3D template to fit your engine and exhaust pipe, then slide onto the actual cowling and use as template to mark the openings required for final cutting.

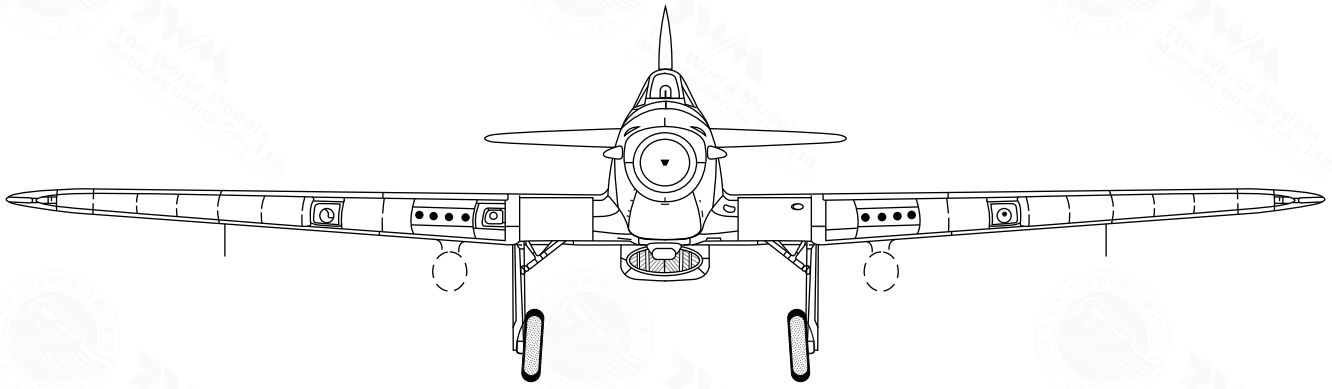

Ducted Fan

Pattern

Warbirds

Funfly

Scale

Electric

Sports

Glider

Trainer

Boat

Accessories

Covering

(Lightex / Toughlon)



**The World Models
Manufacturing Co., Ltd.**
www.theworldmodels.com