

Thank you for choosing CYmodel
Global : www.cymodel.com
Australia : www.austars-model.com
Italia : www.biellaexpress.com

Cessna 195

Item Nr: CY8038



Instruction Manual

Before commencing assembly, please read these instructions thoroughly.

ALMOST - READY - TO - FLY



Warning!

SAFETY PRECAUTIONS This radio control model is not a toy!

- First-time builders should seek advice from people having building experience in order to assemble the model correctly and to produce its performance to full extent.
- Assemble this kit only in places out of children's reach!
- Take enough safety precautions prior to operating this model.
You are responsible for this model's assembly and safe operation!
- Always keep this instruction manual ready at hand for quick reference, even after completing the assembly.
- Could cause serious injury or even death

SPECIFICATION

Wing Span: 2285mm (90in)
Wing Area: 72.2dm² (1120sq.in)
Total Length: 1800 mm (71 in)
Engine :35cc gas engine
Radio : 5 channels ,8 servos

REQUIRED FOR OPERATION (Purchase separately)

- 1** A minimum 5channel radio for airplanes (with 8/9servos).
And dry batteries.

CAUTION: Only use a minimum 5channel radio for airplanes! (No other radio may be used!)

A minimum 5 channel transmitter for airplanes.



12 AA-size Batteries

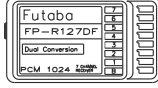

receiver



remote control

For handing the radio properly, refer to its instruction manual.

- 2** Battery (need 2) Switch (need 2)

- 3** Servo(need 8/9 servos)

- 4** Engine and Muffler
Model Airplane engine:35cc gas engine



Muffler



Ignition



- 5** Glue
Epoxy Glue Instant glue

- 6** required for engine starting
Glow engine fuel only.
WARNING: Normal gasoline cannot be used with glow engines.



Fuel Pump

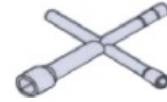

Plug Wrench

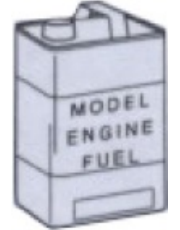

- 7** Silicone Tube Fuel Filter

- 8** Other equipment for enhancing airplane operation & performance

Engine Starter 12V Battery (for starter)

- 9** Purchase a propeller that will match your engine

TOOLS REQUIRED (Purchase separately)

Sharp Hobby Knife



Phillips Screw Driver



Awl



Needle Nose Pliers

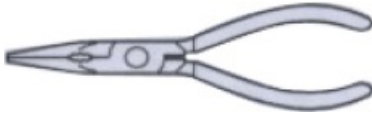

Wire Cutters



Scissors

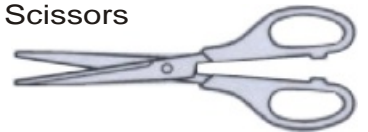

BEFORE YOU BEGIN

- 1 . Read through the manual before you begin ,so you will have an overall idea of what to do.
- 2 . Check all parts .if you find any defective or missing parts .contact your local dealer.
- 3 Symbols used throughout this instruction manual,comprise.

Apply epoxy glue.

Drill holes with the specified Diameter(here:2mm)

Must be purchased separately!

Warning!

Apply instant glue (CA glue,super glue).

Ensure smooth non-binding movement while assembling.

Pay close attention here!

Do not overlook this symbol.

Assemble left and right Sides the same way.

Cut off shaded portion.

Cut off excess.



Accessory list for this page.

	Horn.....	4
	Horn.....	2
	Connecting rod head.....	4
	Rod adjuster.....	4
	1.8X70mm rod.....	4
	3X12mm Tp screw.....	6
	2x30mm Screw.....	6
	2.6X12mm Tp screw.....	16
	2x10mm Screw.....	4
	Hinge.....	6
	Hinge.....	6
	8mm Nut.....	4

1 Install the aileron and flap

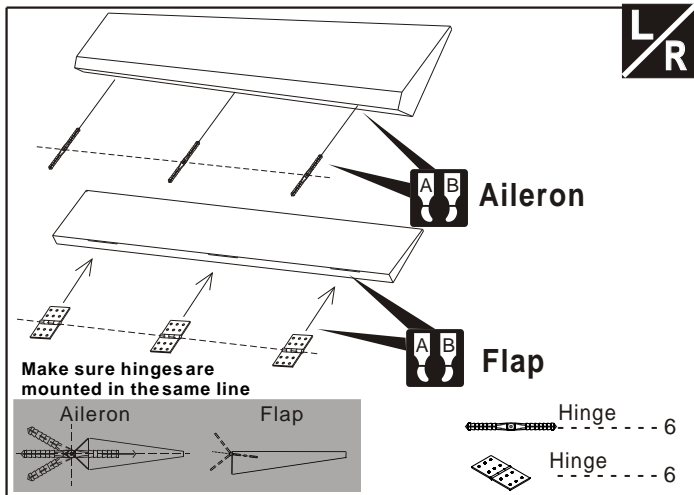

3 Install the servo

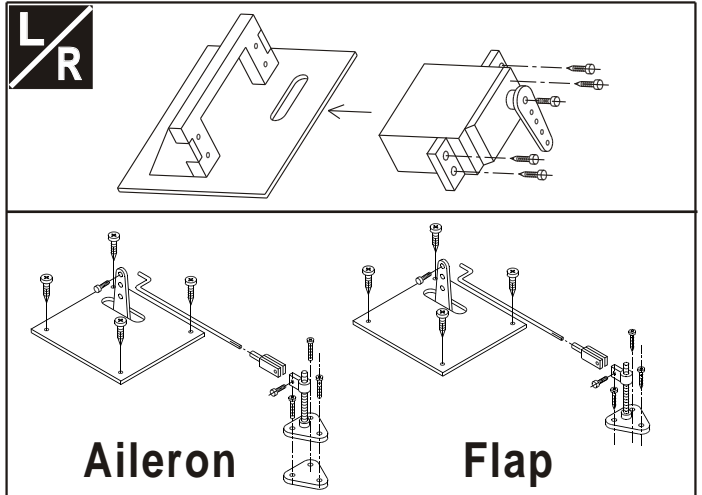

4 Install the servo

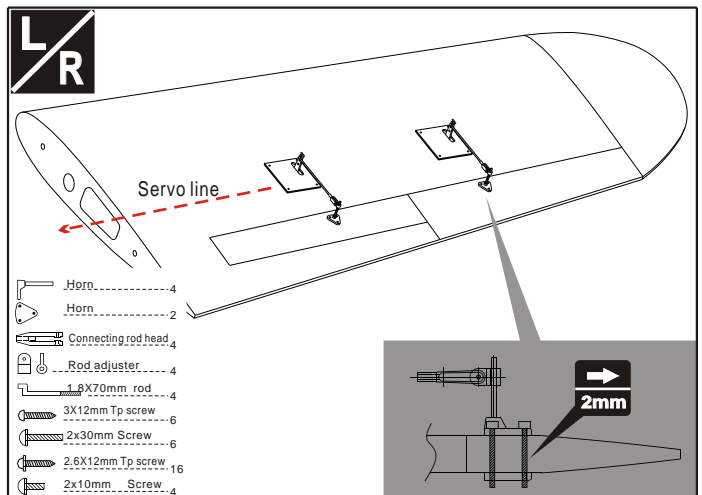

2 Install the aileron and flap

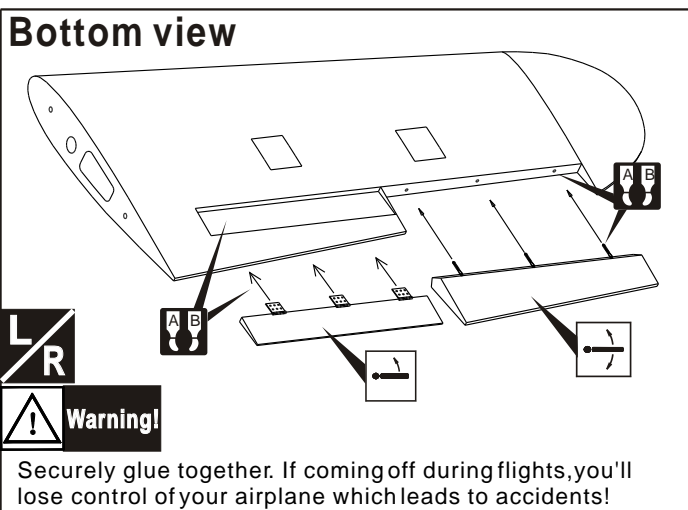

5 Ming wing

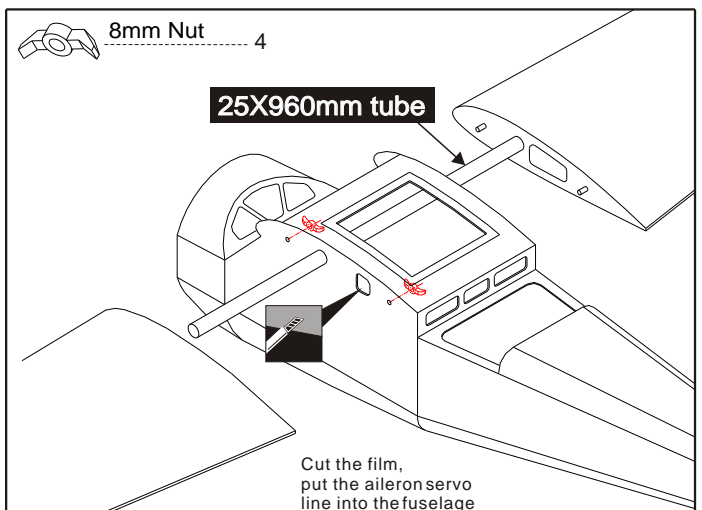



Accessory list for this page.



3.2mm Collar 2



3.2mm Rocker 1



3X3mm Screw 3



3.2mm Nylon Collar 1



Hinge 8

Horizontal/Vertical tail

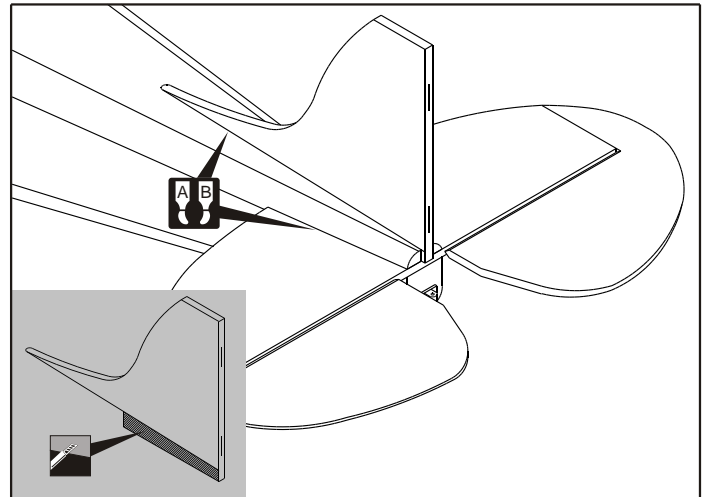

6 Main wing

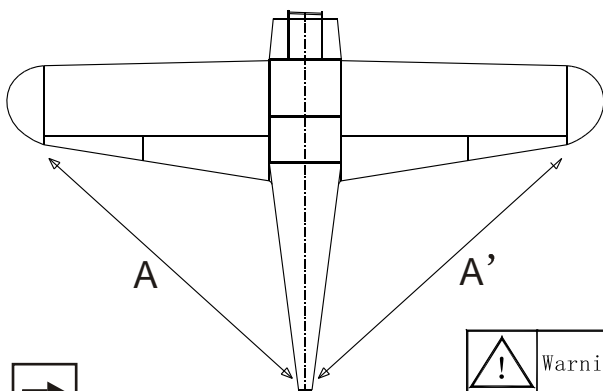

A=A'



Warning!

Securely glue together, if coming off during flights, you'll lose control of your airplane which leads to accidents!

Horizontal/Vertical tail

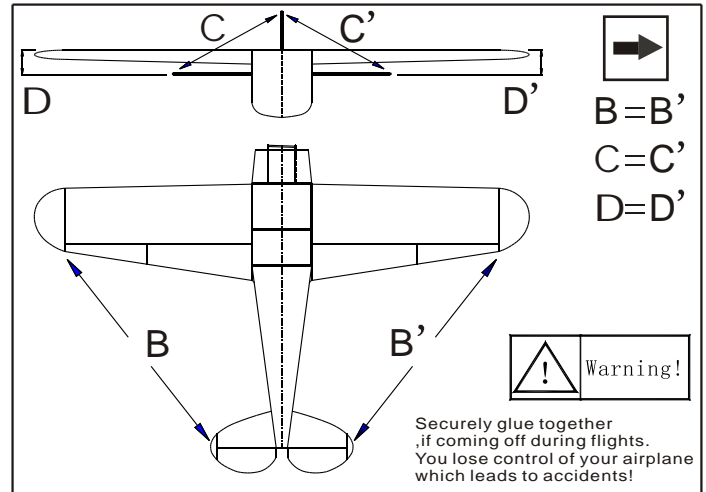

B=B'

C=C'

D=D'



Warning!

Securely glue together, if coming off during flights, you'll lose control of your airplane which leads to accidents!

7 Install the elevator

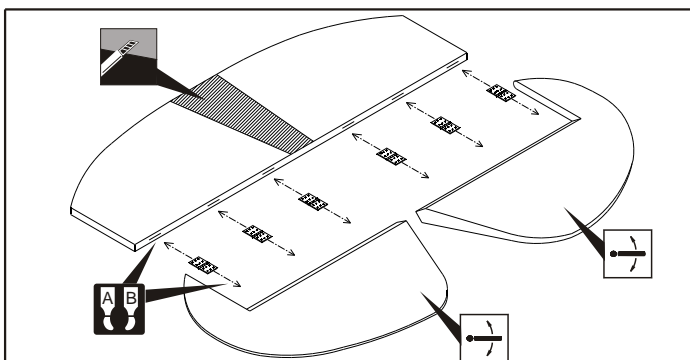

Warning!

Securely glue together. If coming off during flights, you'll lose control of your airplane which leads to accidents!

Hinge 6

10 Install the rudder and tail wheel

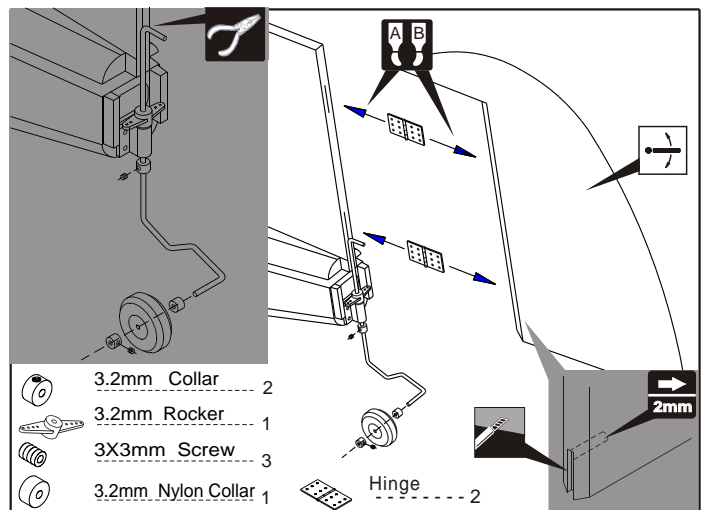

3.2mm Collar 2

3.2mm Rocker 1

3X3mm Screw 3

3.2mm Nylon Collar 1

Hinge 2



Accessory list for this page.

	5X45mm screw	2		2X10mm screw	6
	4X20mm screw	4		Aluminium tube	8
	5mm lock nut	4		Horn	2
	5mm Washer	4		Horn	2
	4mm Washer	4		Rod adjuster	2
	1100mm Steel wire	2		1.8X110mm rod	2
	Rod	4		2x20mm Screw	6
	Rod adjuster	6			

13 Install the main landing gear

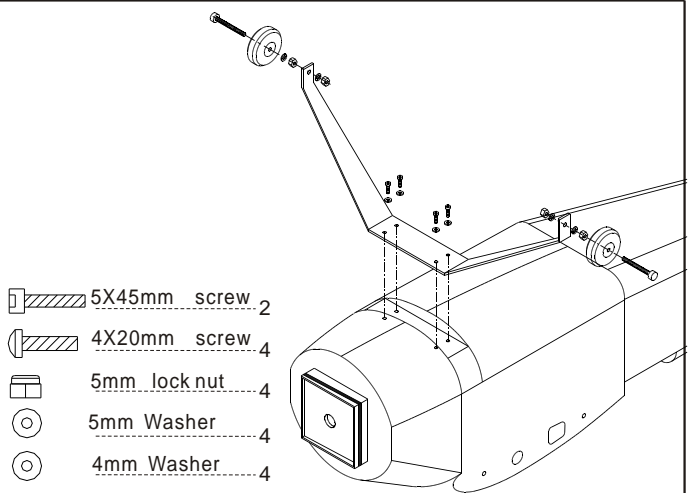

11 Install the rudder servo

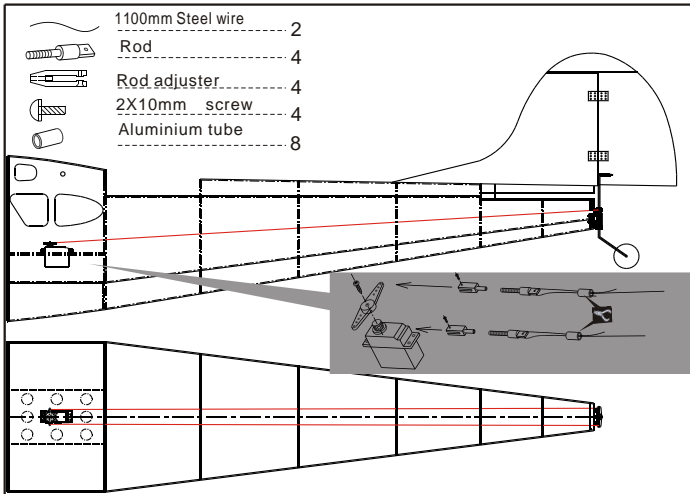

14 Install the engine

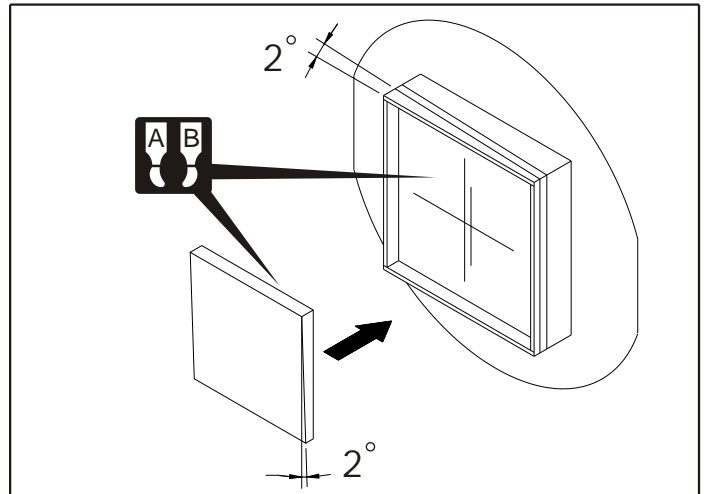

12 Install the elevator servo

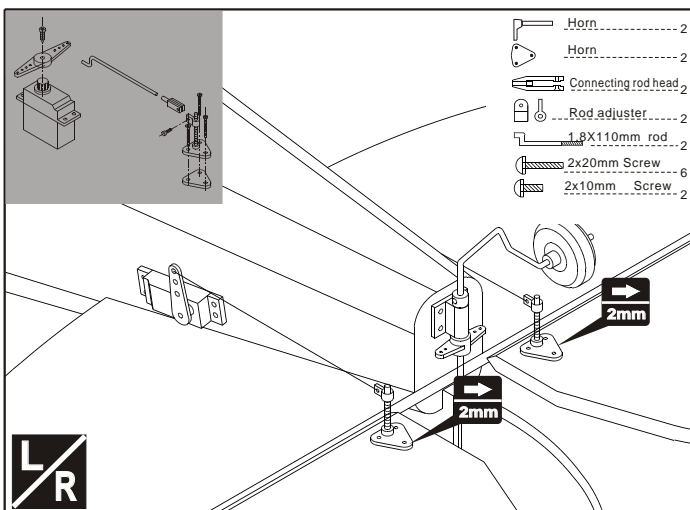



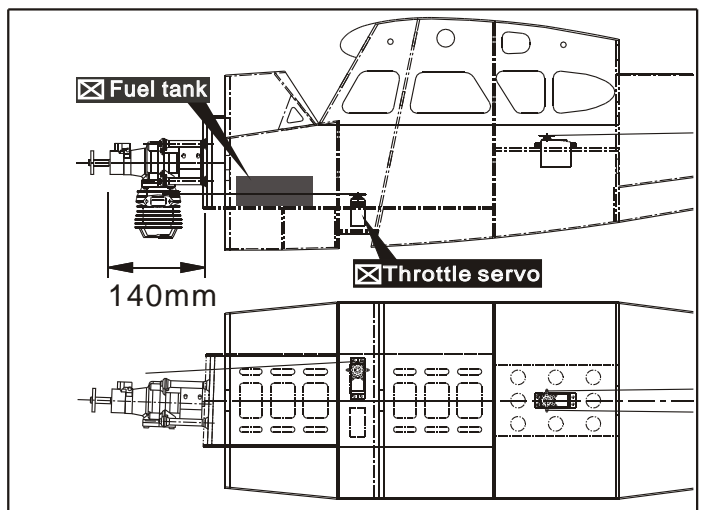

15 Install the engine(35cc gas)





Accessory list for this page.

- | | |
|---|---|
| Linkage Stopper | 1.8X350mm Rod |
|  --- 1 |  --- 1 |
| 2mm Nut | 3X3mm Screw |
|  --- 1 |  --- 1 |
| 2.6X12mm Tp screw | |
|  --- 4 | |

18 Radio Equipment

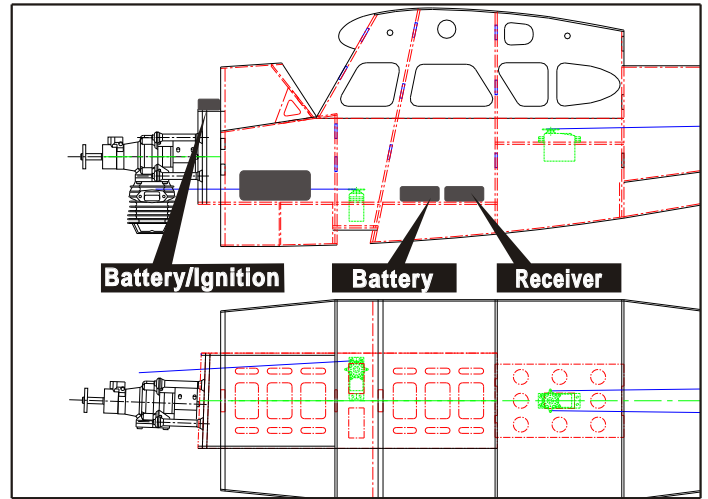

16 Install the throttle servo

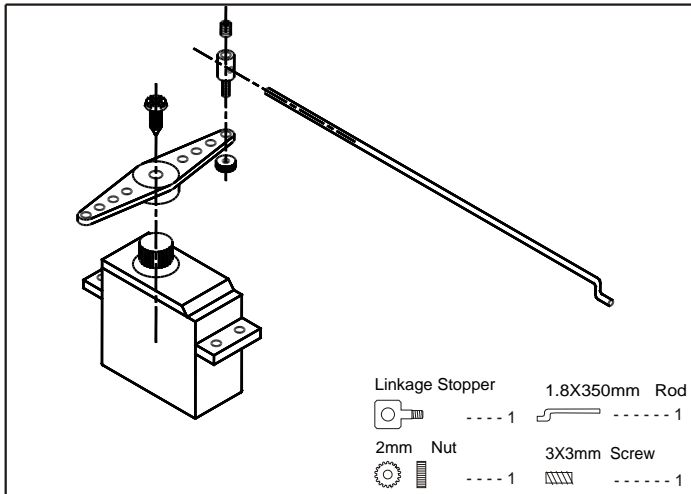

19 Install the cover

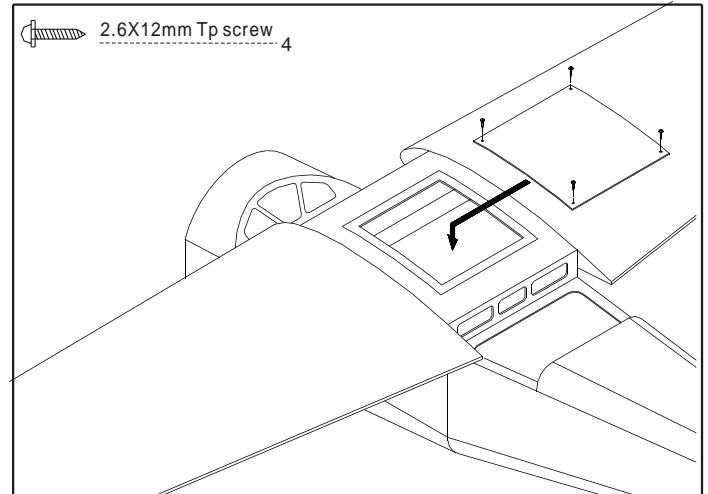

17 Assembly of the full tank

After confirming the position (see front of fuel tank). Insert and tighten the screw.

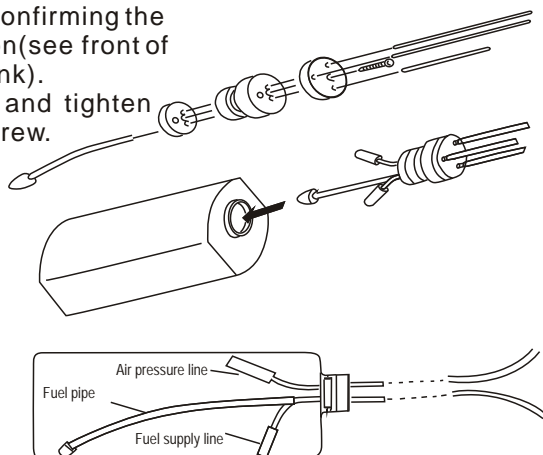

20 Install the cover





Accessory list for this page.

2.6X12mm Tp screw



3X14mm screw

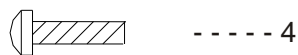

3mm Washer

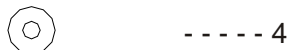

23 Install the thr cowling



3X14mm screw 3mm Washer



21 Install the afterbody

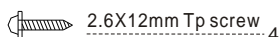

24

22 Install the canopy



Cut away the surplus parts of canopy, care fully along the shaded line.



25

26 Adjustment.

Adjust the travel of each control surface to the values in the diagrams.
These values fit general flight capabilities.
Readjust according to your needs and flight level.

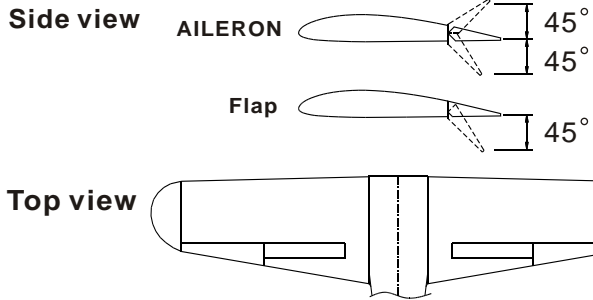

28 Adjustment

Adjust the travel of each control surface to the values in the diagrams.
These values fit general flight capabilities.
Readjust according to your needs and flight level.

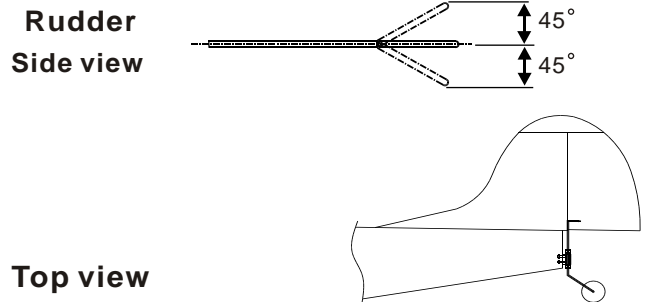

27 Adjustment.

Adjust the travel of each control surface to the values in the diagrams.
These values fit general flight capabilities.
Readjust according to your needs and flight level.

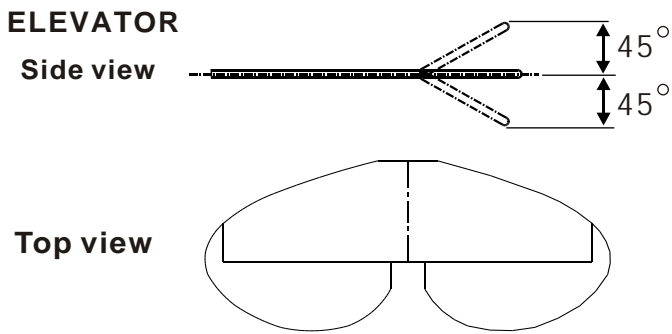

29 Adjustment.

Never fly before checking the Cg ' s required position.
In order to obtain the CG specified ,reposition the receiver and battery.

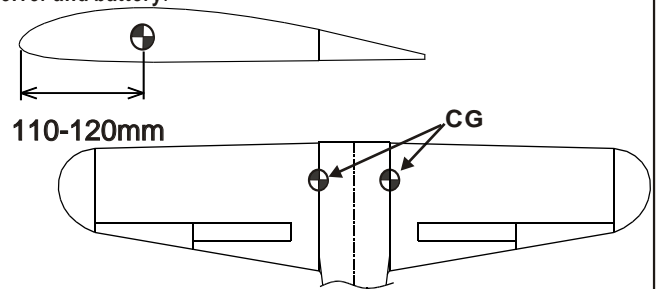

警告
Warning!

NEVER fly the model without well balancing.